

VELA INDUSTRIAL

BARRIERA OLEODINAMICA
HYDRAULIC BARRIER
BARRIERE HYDRAULIQUE

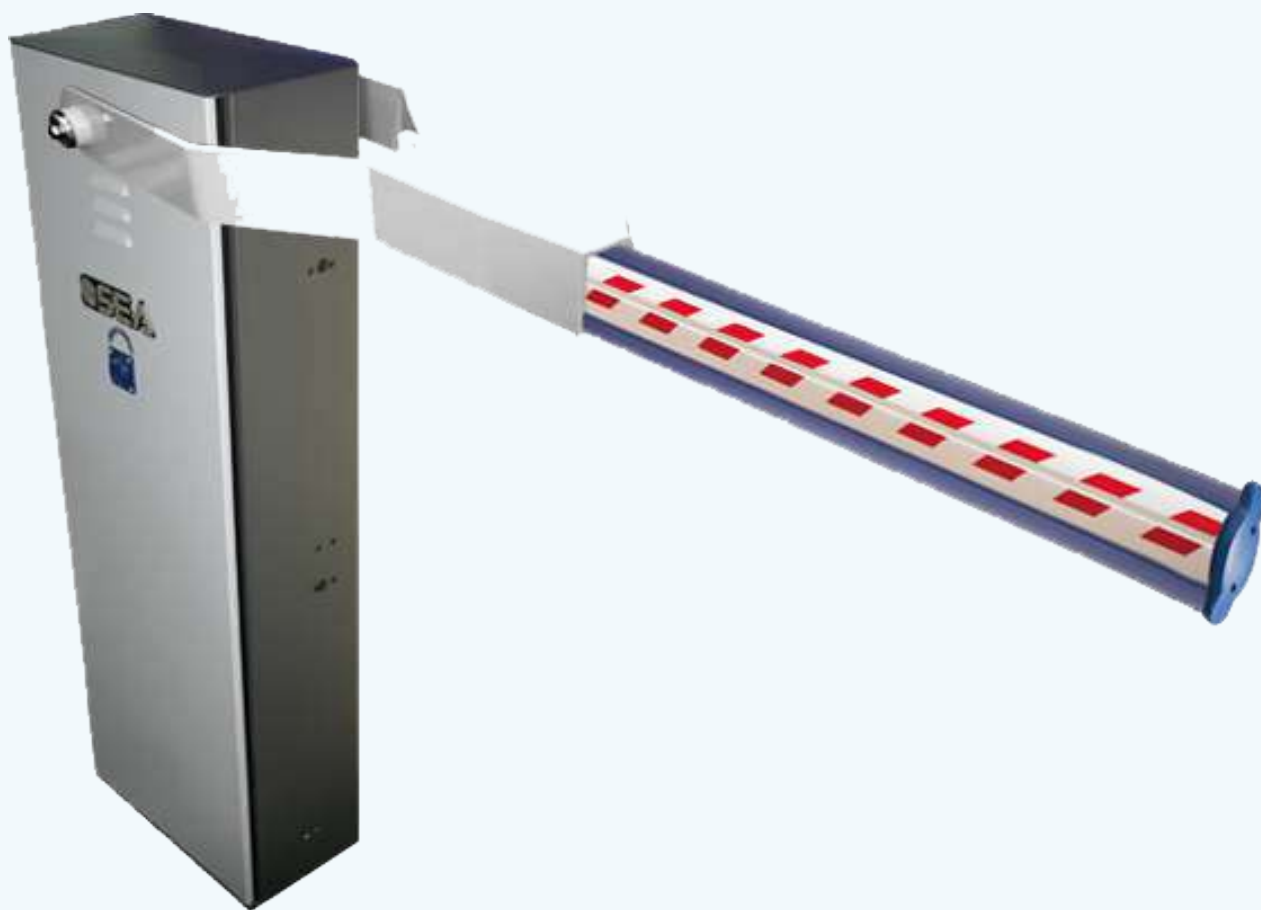

SEA S.p.A.

Zona Industriale Sant'Atto - 64100 - Teramo - ITALY
Telephone: + 39 0 861 588341 - Fax: + 39 0 861 588344

www.seateam.com

TECHNICAL FEATURES

VELA INDUSTRIAL is an hydraulic barrier for semi-intensive applications in large driveways, designed for arms up to 8 m

All models are **IRREVERSIBLE**, to allow a perfect and safe closing of the arm

The barrier is equipped with a **MANUAL RELEASE SYSTEM** - placed inside the barrier housing - which allows manual opening and closing in the event of a power outage.

VELA INDUSTRIAL is also equipped with an **electronic inversion device via ABSOLUTE ENCODER**, which makes it safe and reliable and allows to comply with the Laws in force in the Countries where the barrier is installed.

The **ELECTRONIC DECELERATION SYSTEM**, combined with the absolute encoder, guarantees total control of the inertia forces.

The barrier is also equipped with **BY-PASS VALVES** which allows to adjust the thrust force and thus ensure anti-crushing safety.

The housing is made of cataphoresis treated steel and painted in polyester for outdoor use, for excellent resistance to atmospheric agents (*the casing is also available in STAINLESS STEEL, upon request*)

COMPONENTS

- 1 - ADJUSTABLE MECHANICAL STOPS
- 2 - ABSOLUTE ENCODER
- 3 - GALVANIZED STEEL ROCKER ARM
- 4 - BALANCING SPRING
- 5 - HYDRAULIC UNIT
- 6 - BY-PASS VALVES
- 7 - MOTOR RELEASE SCREW
- 8 - BOX WITH ELECTRONIC CONTROL UNIT
- 9 - GALVANIZED STEEL FOUNDATION PLATE
- 10 - PISTON
- 11 - BREATHER CAP (SEE CHAPTER 10)
- 12 - CASING DOOR
- 13 - LOCK WITH DIN KEY

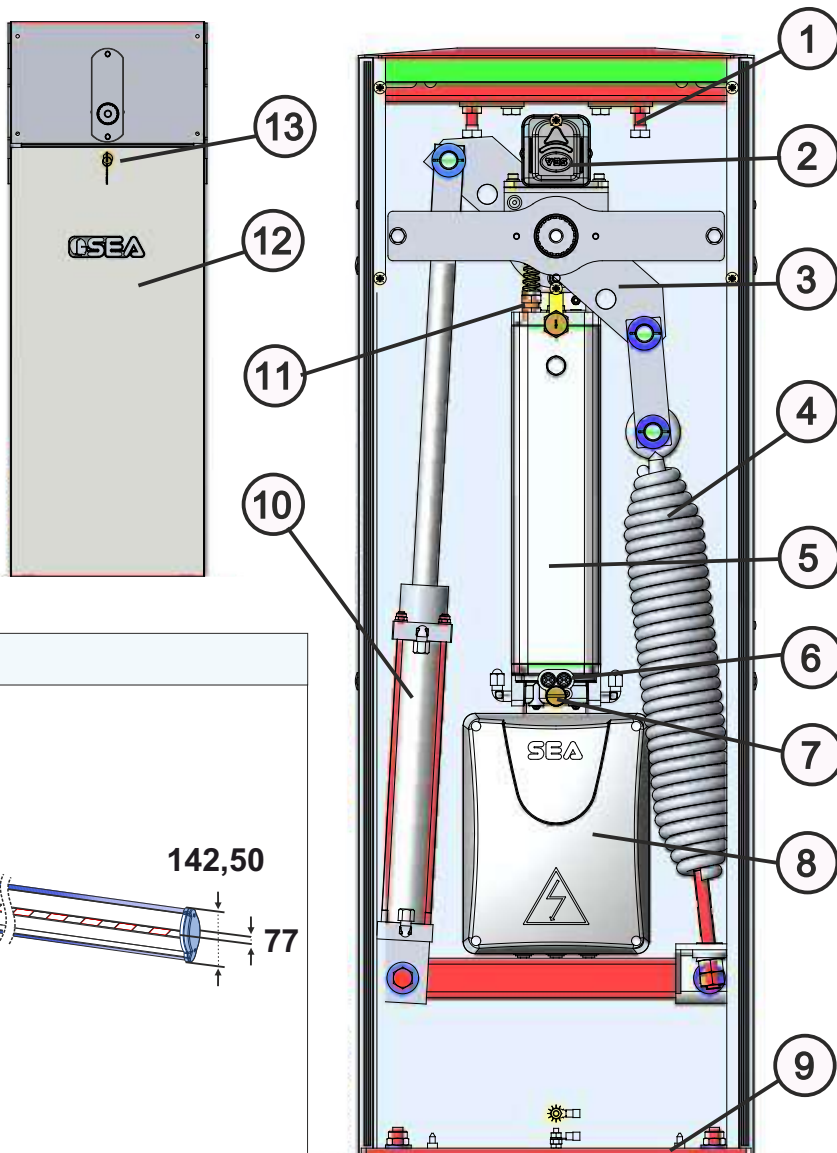

DIMENSIONS (mm)

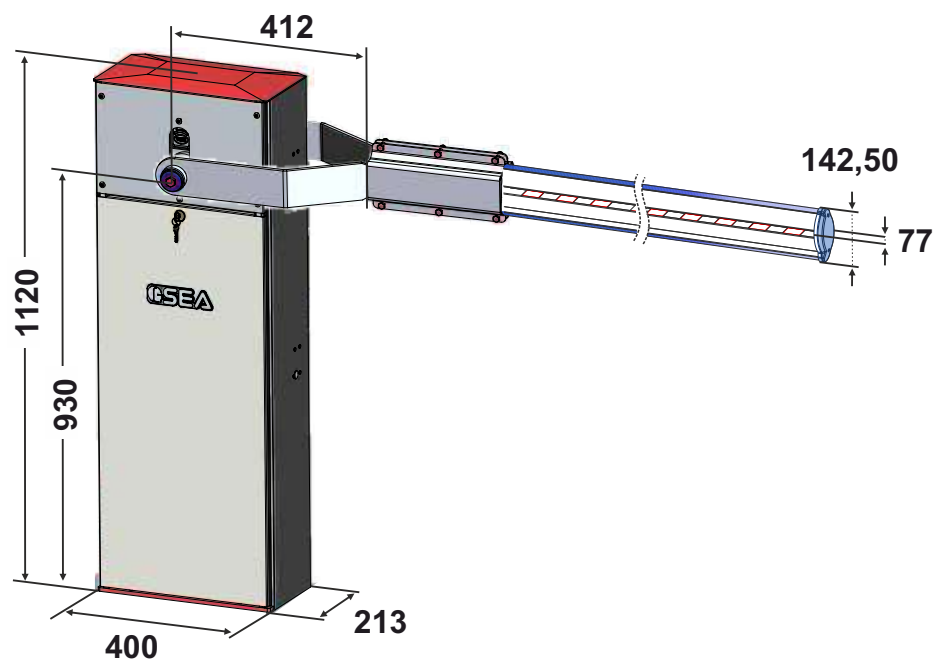

Fig. 2

Fig. 1

TECHNICAL DATA	VELA INDUSTRIAL 230V - IV	VELA INDUSTRIAL 120V - IV
POWER SUPPLY	230V (±5%) 50/60 Hz	120V (±5%) 50/60 Hz
POWER	220 W	220 W
MOTOR ROTATION SPEED	1430 rpm	1550 rpm
USAGE RATE	75%	75%
OPERATING TEMPERATURE	- 20° C + 55° C	- 20° C + 55° C
THERMAL PROTECTION	130° C	130° C
OPERATOR WEIGHT	85 Kg	85 Kg
OIL TANK CAPACITY	1,5 L	1,5 L
PROTECTION CLASS	IP 55	IP 55
OPENING/CLOSING TIME	5,5 / 11 seconds	5,5 / 11 seconds
MAX ARM LENGTH	8 meters - <i>fork bracket included</i>	8 meters - <i>fork bracket included</i>

➔ *The indicated usage rate is valid only for the first operating hour and at a 20°C temperature*

➔ *The usage rate is valid only if all the arm length parameters and the respective speeds are respected; refer to this table and to those below*

➔ *Speed setting must respect the minimum value indicated in the «MINIMUM OPENING TIME» column which varies according to the arm length; **DO NOT** set values lower than the minimum times indicated*

ARMS SPEED CHART - VELA INDUSTRIAL (E/A - IV)

ARM LENGTH (m)	SPRING WIRE DIAMETER (mm)	SPRING CODE	ARM TYPE	MINIMUM OPENING TIME (s)	DEFAULT OPENING TIME (s)	SPRING END-ROD JOINT COLOR
5	10,5	66400005	SPLIT + JUICE	5,5	7,5	RED
6	11	66400010	SPLIT + JUICE	6,5	8,5	YELLOW
7	11,5	66400011	SPLIT + JUICE	7,5	9,5	GREEN
7,5	12,5	66400020	SPLIT + JUICE	8,5	10,5	PINK
8	12,5	66400020	SPLIT + JUICE	9	11	PINK

ARM + SKIRT SPEED CHART

ARM LENGTH (m)	SPRING WIRE DIAMETER (mm)	SPRING CODE	ARM TYPE	MINIMUM OPENING TIME (s)	DEFAULT OPENING TIME (s)	SPRING END-ROD JOINT COLOR
6	11	66400010	-	6,5	8,5	YELLOW
7	11,5	66400011	-	7,5	9,5	GREEN

ARM + DOUBLE SKIRT SPEED CHART

ARM LENGTH (m)	SPRING WIRE DIAMETER (mm)	SPRING CODE	ARM TYPE	MINIMUM OPENING TIME (s)	DEFAULT OPENING TIME (s)	SPRING END-ROD JOINT COLOR
5,5	11	66400010	-	6,5	8,5	YELLOW
6,5	12,5	66400020	-	7,5	9,5	PINK

1 - LEFT OR RIGHT HAND ARM ARRANGEMENT

The **VELA INDUSTRIAL** barrier can be installed either for left or right-hand opening

The opening direction depends on the position of the balancing spring - see **chapter 4**:

If the spring is left-hand installed, the arm opens to the left;

If the spring is right-hand installed, the arm opens to the right;

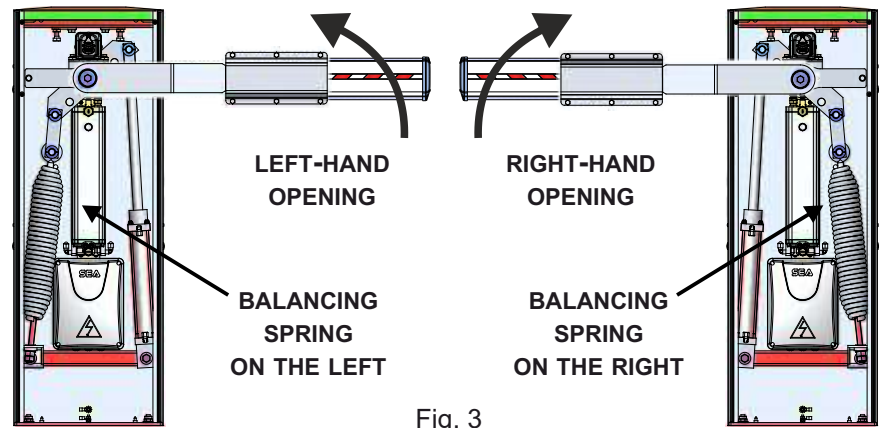

Fig. 3

2 - INSTALLATION OF THE FOUNDATION PLATE

To install the foundation plate it is necessary to:

2.1. Prepare a concrete slab according to the dimensions shown in Fig. 4;
The anchor bolts must be concreted inside the slab. The foundation plate must be fixed on the anchor bolts and concreted on the slab

IF ALLOWED BY THE STRUCTURE, IT IS RECOMMENDED TO LIFT THE FOUNDATION PLATE OF ABOUT 50mm FROM THE GROUND, TO AVOID WATER PUDDLING.

2.2. Insert the flexible plastic pipe ($\varnothing 30$ mm at least) for the electric cables into the special hole of the plate

2.3. Make sure that the plate is perfectly leveled and that the anchor bolts come out of the plate for 30 mm, as shown in Fig. 5

2.4. Fill up the excavation using «R425» concrete; carefully level the plate on the concrete.

DIMENSIONS IN mm

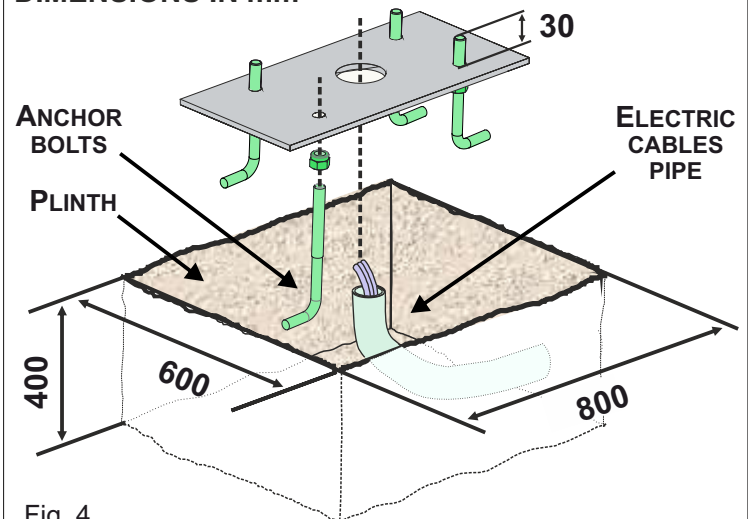

Fig. 4

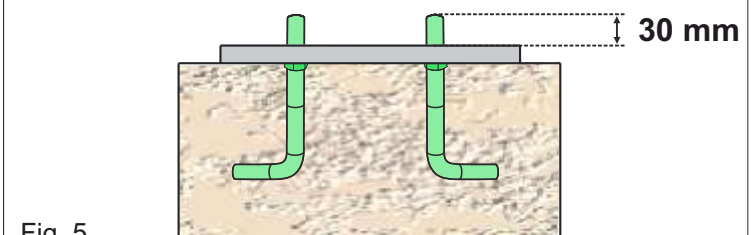

Fig. 5

3 - INSTALLATION OF THE BARRIER ON THE FOUNDATION PLATE

3.1. Place the barrier housing on the foundation plate by matching the base holes with the anchor bolts coming out of the plate

3.2. Make sure that the electric cables pipe has perfectly passed through the large hole at the base of the barrier housing

3.3. Fix the barrier housing to the foundation plate using the nuts and washers provided - Fig. 6 and Fig. 7

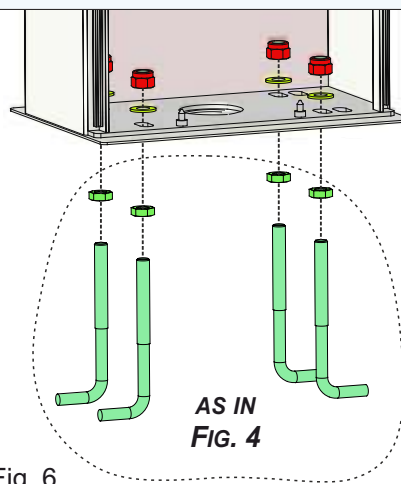

Fig. 6

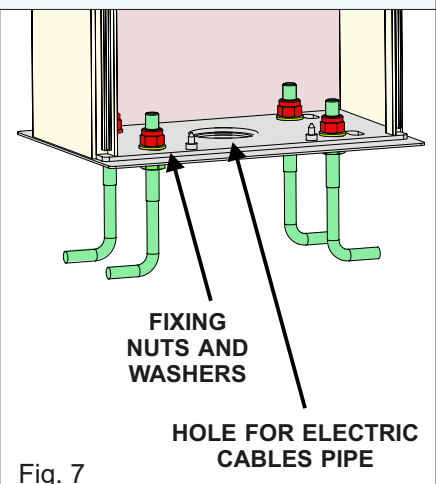

Fig. 7

4 - LEFT OR RIGHT HAND INSTALLATION OF THE PISTON AND SPRING

VELA INDUSTRIAL barrier is supplied with left-hand opening arm as standard; it is possible to change the opening direction by moving both the piston and the balancing spring.

4.1. Before carrying out the moving operation, release the operator - *see chapter 12* - and, on the hydraulic unit, **LOOSEN THE TWO FITTINGS OF THE HYDRAULIC PIPES BY HALF A TURN** (*pipes connecting hydraulic unit to the piston*) to simplify the piston rotation.

Be careful not to choke the hydraulic pipes! (*not visible in the figures!*)

4.2. CHANGE OF THE OPENING DIRECTION - (*RIGHT-HAND OPENING*)

- unscrew and pull out the balancing spring - Fig. 10
- unscrew the hydraulic piston - Fig. 8, release it from the hydraulic pipes avoiding that they intertwining, then place the piston on the opposite side of the barrier and tighten with the fixing screws - Fig. 9
- lubricate the piston rod-end spherical bearing with *DIN 51502 KP 2 N-20 - K 2 K-20* grease
- place the balancing spring on the opposite side of the barrier, greasing the parts indicated in Fig. 11

4.3. In case of ordinary replacement of the spring, according to the barrier opening direction, disassemble the old spring and reassemble the new one following the tightening instructions in Fig. 10 or in Fig. 11

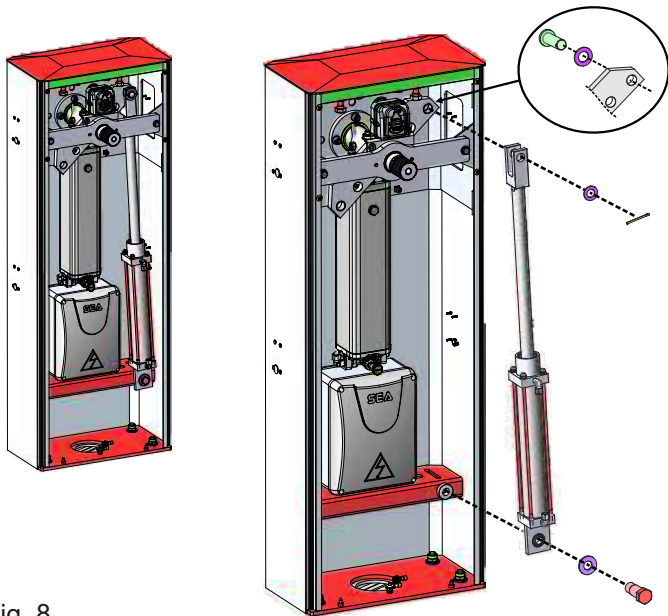

Fig. 8

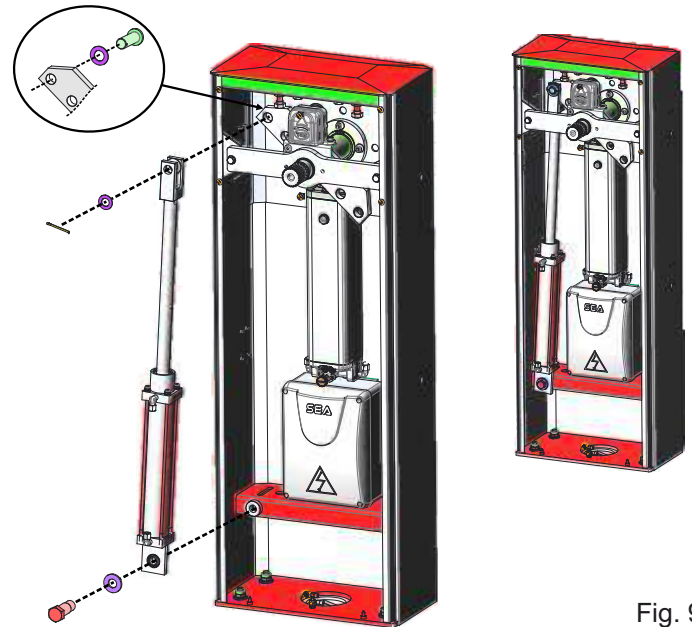
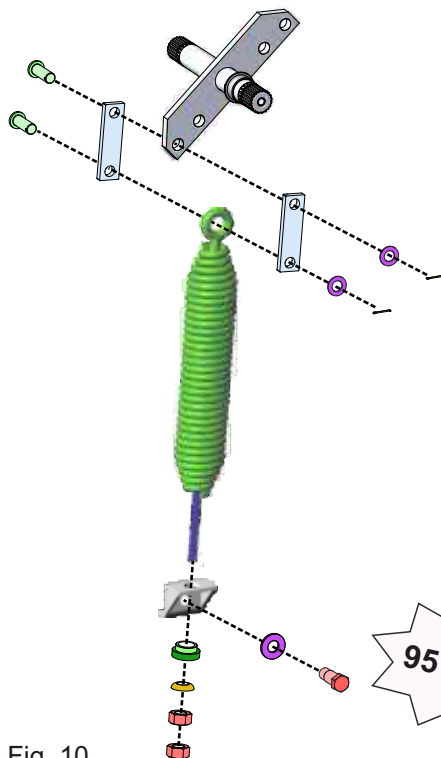
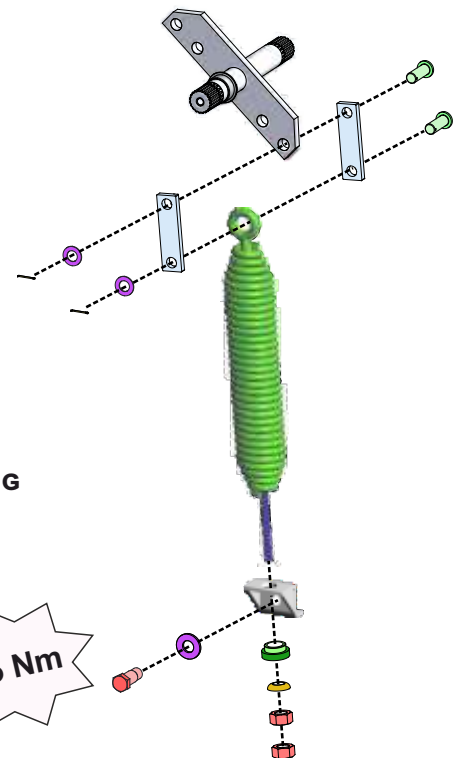

Fig. 9



**LEFT-HAND
SPRING MOUNTING
FOR LEFT-HAND
OPENING ARM**

**RIGHT-HAND
SPRING MOUNTING
FOR RIGHT-HAND
OPENING ARM**



**WHEN REASSEMBLING THE SPRING,
LUBRICATE WITH GREASE
(*DIN 51502 KP 2 N-20 - K 2 K-20*)
ALL PARTS TO BE ASSEMBLED
SUCH AS SCREWS, BOLTS
THE SPRING ROD-END SPHERICAL BEARING
AND THE ROCKER ARM**

95 Nm

95 Nm

Fig. 10

Fig. 11

5 - ARM INSTALLATION ON THE BARRIER

Fig. 12

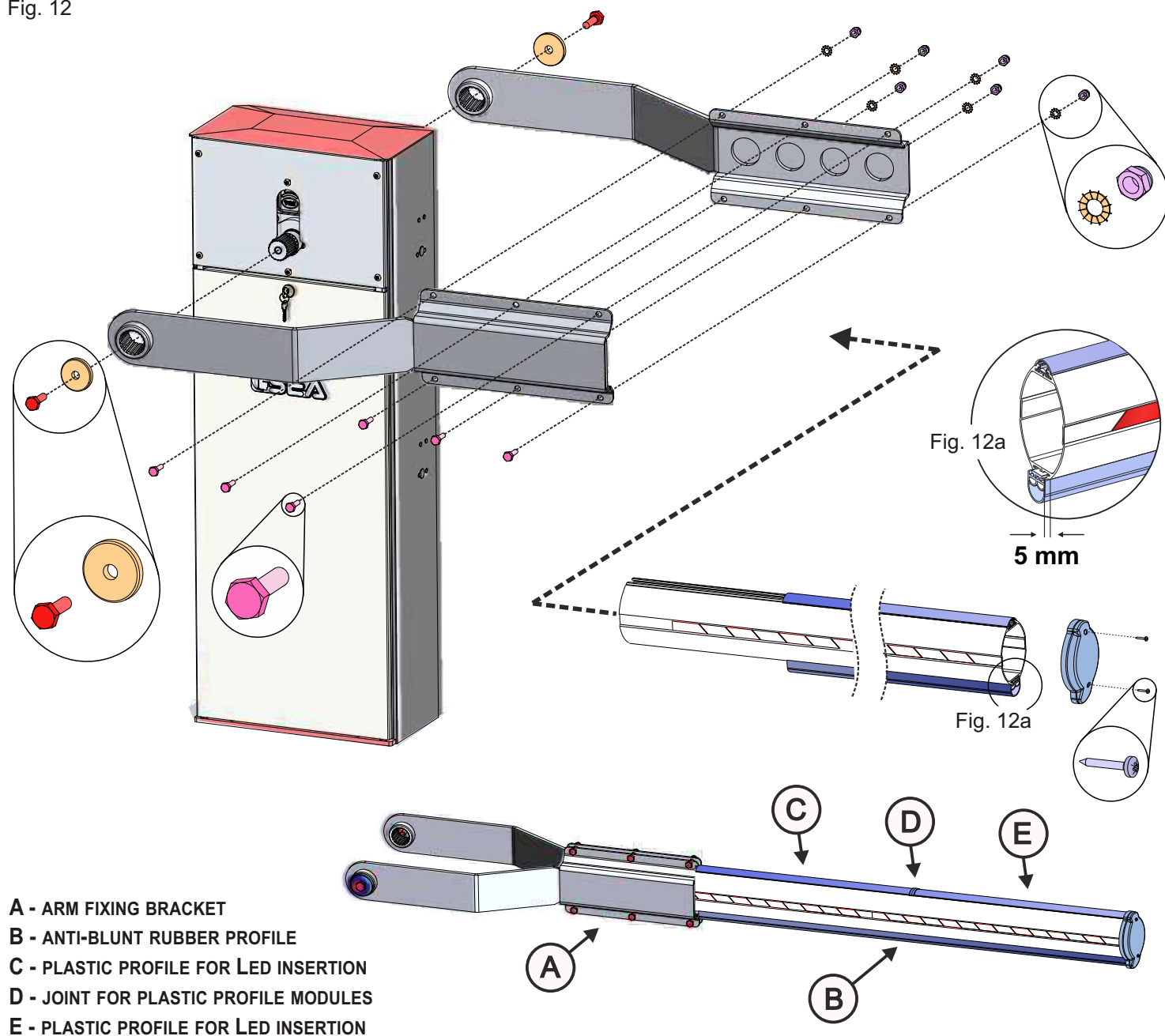

The arm of the VELA INDUSTRIAL barrier is made up of two modules «SPLIT» and «JUICE», joined by a joint. «SPLIT» has a fixed length of 4 metres; «JUICE» is of variable length, depending on your needs. **For the assembly of the modules, please refer to the arm technical instructions.**

5.1. INSTALLATION OF THE PLASTIC PROFILE FOR LED LIGHTS INSERTION (LED LIGHTS ARE OPTIONAL)

The plastic profile must be mounted on the upper side of the arm;
 Insert the first module of the plastic profile «C» in the guide up to the edge of the arm fixing bracket «A»;
 Insert the joint «D» followed by the next plastic profile module «E» - repeat for the following modules, each spaced out by the joint, up to the end of the arm; cut out the exceeding module, if necessary.

5.2. INSTALLATION OF THE ANTI-BLUNT RUBBER PROFILE

The anti-blunt rubber profile must be mounted on the lower side of the arm;
 Insert the rubber profile «B» in the guide, sliding up to the edge of the arm fixing bracket «A»;



CUT OUT THE EXCEEDING RUBBER PROFILE MAKING SURE IT COMES OUT OF THE ARM FOR 5 MM - FIG. 12A

➔ **For arms longer than 4 metres, it is recommended to install the fork support on the ground (to be installed at the end of the arm) or to install the folding support (to be installed on the arm)**

6 - SKIRT INSTALLATION (OPTIONAL)

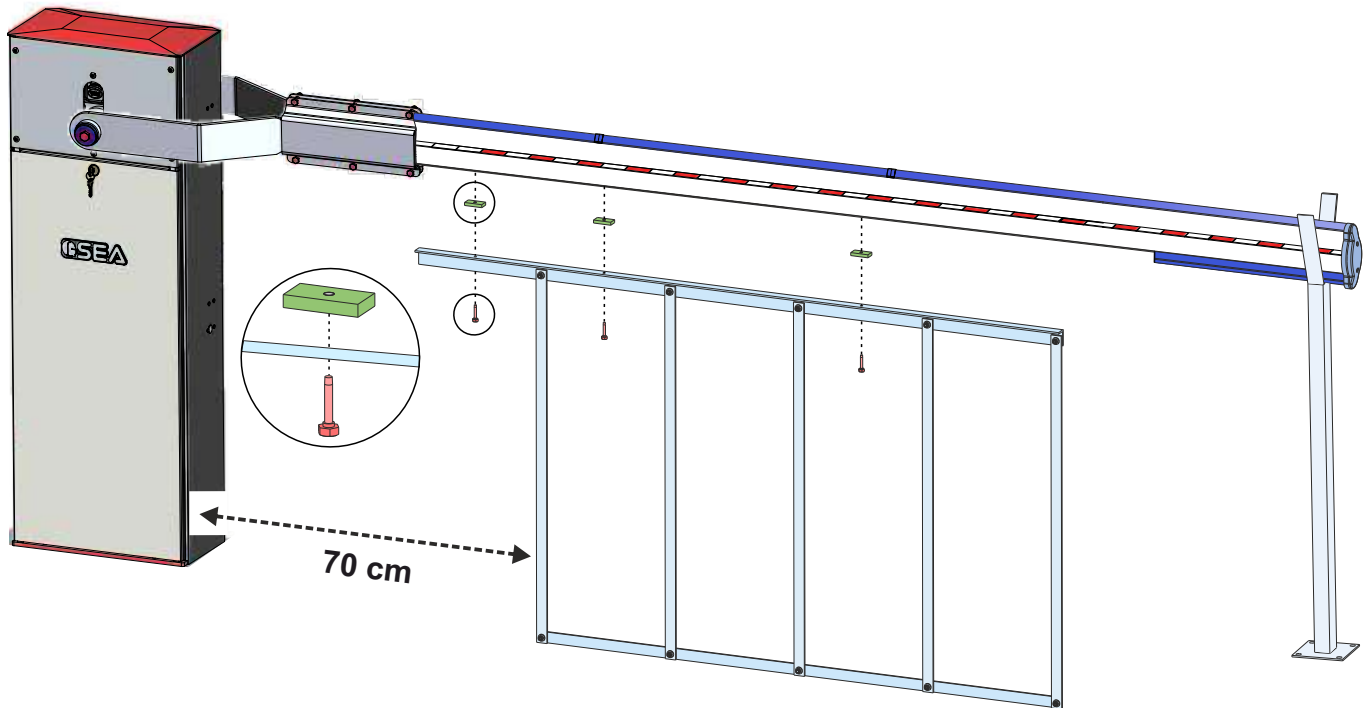

Fig. 13

7 - ARM BALANCING OPERATION

! For the correct balancing of the arm, it is recommended to unscrew the piston from the rocker arm, as shown in CHAPTER 4 - Fig. 8 or Fig. 9

7.1. Release the arm using the manual release - **chapter 12** - in order to move it manually

7.2. Place the arm halfway, approximately 45°

7.3. Tighten or loosen the spring-tensioner nut until the spring counter-balances the weight of the arm placed at 45°; The optimal balancing position is when the arm stays in the position shown in Fig. 14

7.4. Once the arm has been balanced, lock the spring-tensioner nut by tightening the counter-nut.

7.5. Re-lock the arm as shown in **chapter 12**

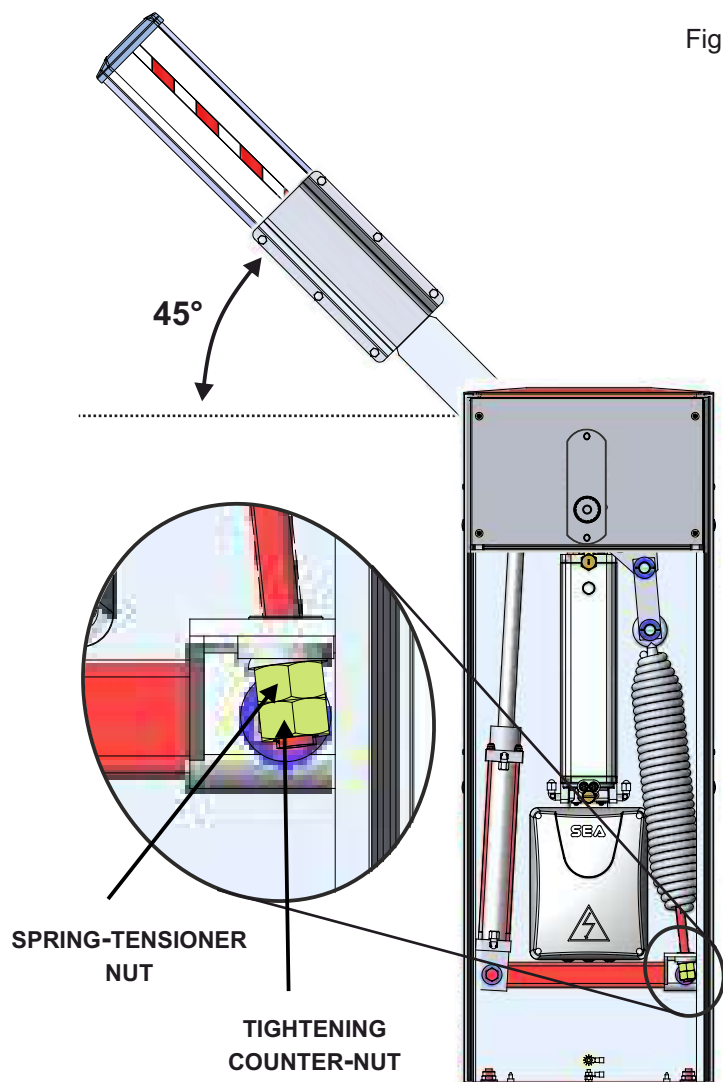

Fig. 14

8 - ARM LEVELING

⚠ Carry on the following procedure only if the arm does not stay perfectly horizontal (in closing) or vertical (in opening) at the end of its stroke

8.1. Release the arm using the manual release - **chapter 12** - in order to move it manually

8.2. Unscrew the metal plate above the casing door and lower it by sliding it onto the fork fixing shaft, leaving the leveling nuts uncovered - Fig. 15a

8.3. Loosen the nut «B» - Fig. 15b

8.4. Tighten or loosen the screw «A» until the arm gets in vertical position in opening and in horizontal position in closing;

8.5. Once a perfect leveling has been achieved, lock the screw «A» by tightening the nut «B»

8.6. Re-lock the arm as shown in the **chapter 12**

8.7. Lift and screw the plate back on

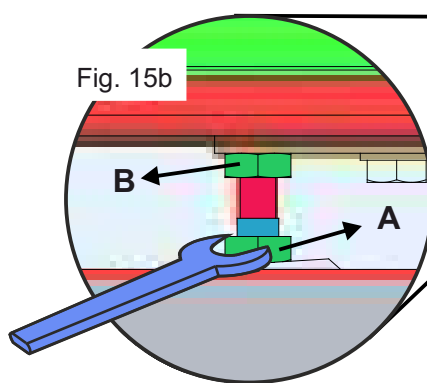
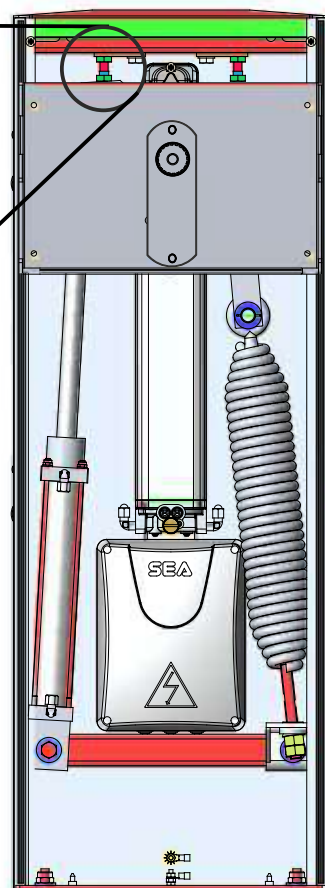
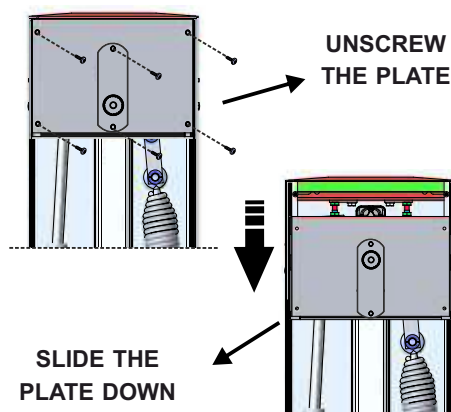

Fig. 15b

Fig. 15a



9 - ADJUSTMENT OF THE THRUST FORCE (BY-PASS VALVES)

⚠ The VELA INDUSTRIAL barrier is factory set to a force of 15 KgF in order to ensure the anti-crushing safety, so it is recommended to modify this setting only in case of absolute need!

9.1. If necessary, adjust the thrust force of the barrier through the By-Pass valves placed on the front side of the hydraulic unit - Fig. 16

- Turn clockwise to increase the force;
- Turn counter-clockwise to decrease the force;

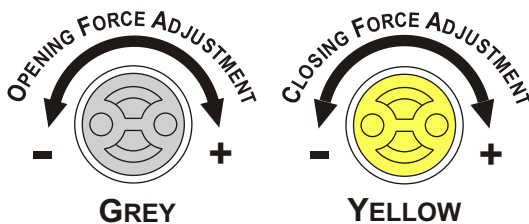

BY-PASS VALVES

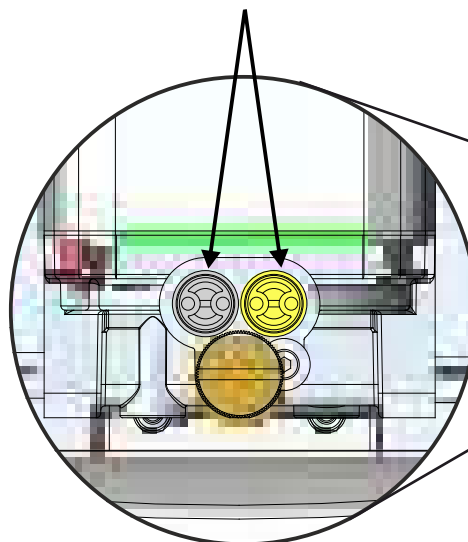
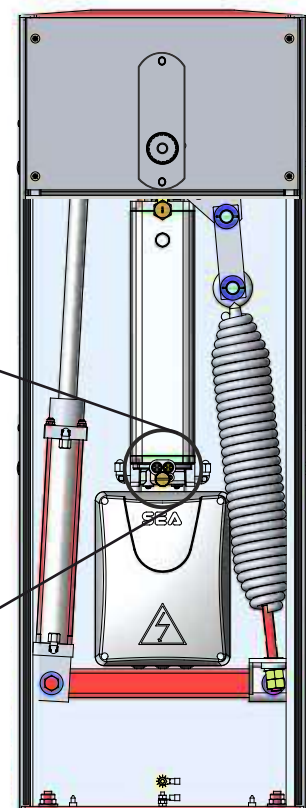

Fig. 16



10 - BREATHER CAP REPLACEMENT

10.1. Before starting the barrier, remove the red transport cap and replace it with the black one supplied and equipped with the airhole;
The cap is on the top of the hydraulic unit
- Fig. 17

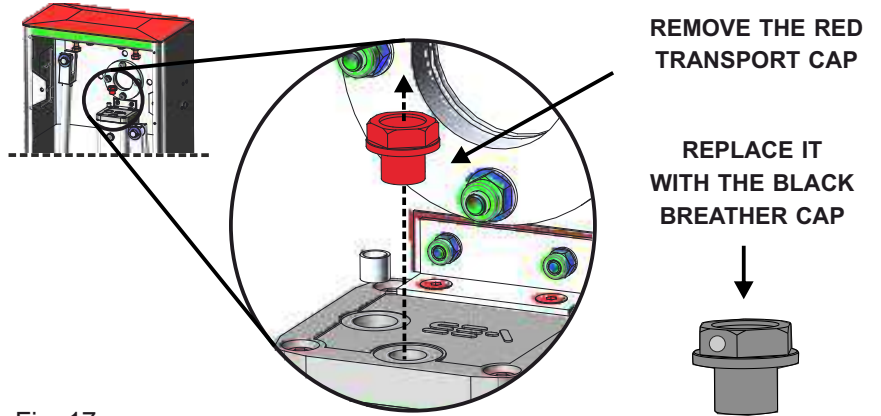

Fig. 17

11 - ELECTRIC WIRINGS

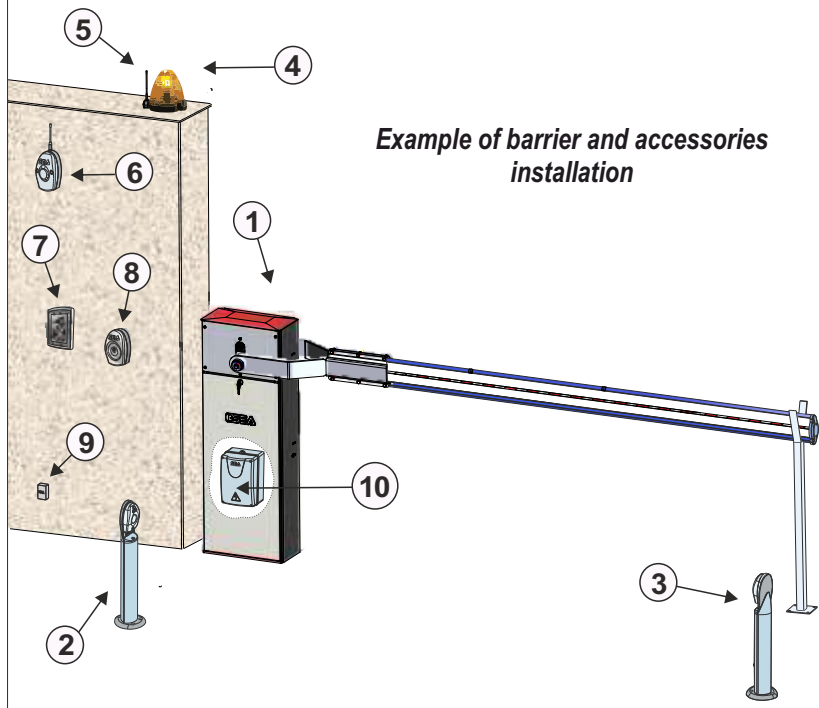

Fig. 18

RECOMMENDED CABLES NUMBER AND SECTION FOR WIRINGS ON CONTROL UNIT

- | | | |
|--------------------------|---|-----------|
| 1) BARRIER (MOTOR) | → | 4 x 1,5 |
| 2) PHOTOCELL TX | → | 2 x 0,5 |
| 3) PHOTOCELL RX | → | 4 x 0,5 |
| 4) FLASHING LAMP | → | 2 x 0,5 |
| 5) ANTENNA | → | 1 x RG58 |
| 6) EXTERNAL RECEIVER | → | 4 x 0,5 |
| 7) KEYPAD | → | 4 x 0,5 |
| 8) KEY-BUTTON | → | 4 x 0,5 |
| 9) DIFFERENTIAL 16A/30mA | → | 3 x 1,5 * |
| 10) CONTROL UNIT BOX | | |

* Increase the cable section in case of high distance from the control unit

PART FOR BOTH INSTALLER AND END-USER

ALL THE UNLOCKING AND LOCKING OPERATIONS AND ALL PERIODIC MAINTENANCE OPERATIONS MUST BE CARRIED OUT IN ABSENCE OF POWER SUPPLY!

12 - RELEASE SYSTEM
12.1. TO RELEASE THE BARRIER

- Open the barrier housing door, using the special key supplied - Fig. 19
- Turn the release screw 180° counter-clockwise with a screwdriver (*the screw is on the front side of the hydraulic unit*) - Fig. 20
- Manually move the arm

12.2. TO LOCK THE BARRIER

- Turn the release screw clockwise with the screwdriver, up to it stops
- Lock the barrier housing door

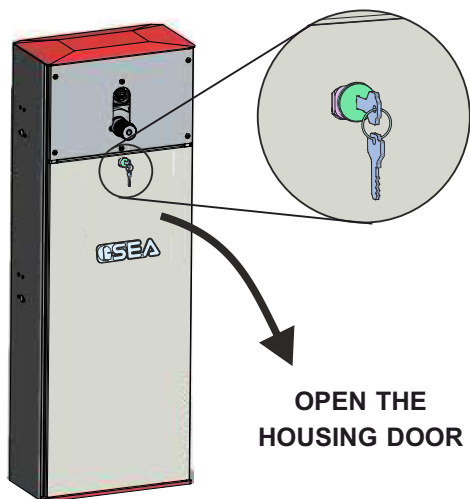

Fig. 19

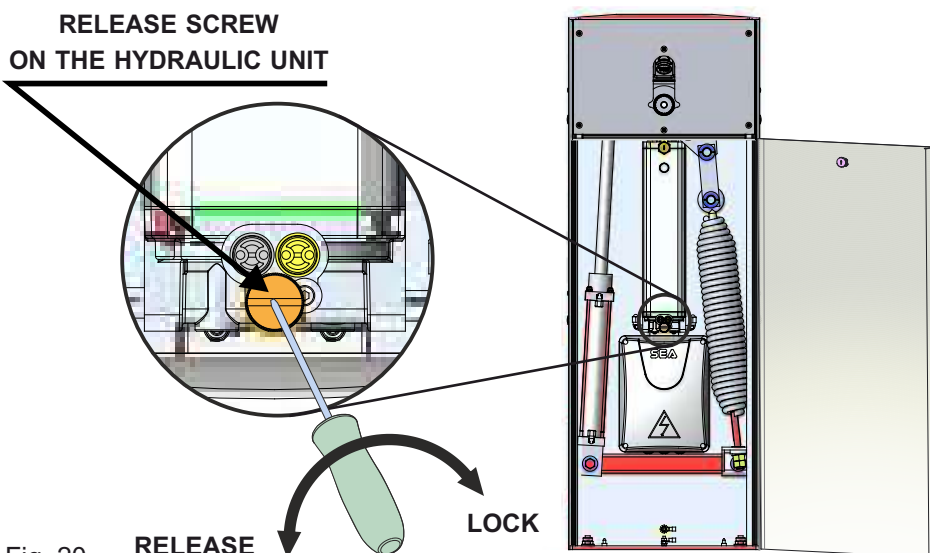

Fig. 20

13 - PERIODIC MAINTENANCE - FOR INSTALLERS ONLY!

LUBRICATE THE SPRING AND PISTON ROD-END SPHERICAL BEARINGS ON THE ROCKER ARM	ANNUAL
CHECK THE CONDITION AND THE CORRECT OPERATION OF THE BALANCING SPRING	ANNUAL
CHECK THE CORRECT OPERATION OF THE RELEASE SYSTEM	ANNUAL
CHECK ALL THE FASTENING SCREWS (<i>ARM, ROCKER ARM AND HOUSING FASTENING SCREWS</i>)	ANNUAL
CHECK THE CONDITION OF THE ELECTRIC CABLES	ANNUAL



ALL OPERATIONS MUST BE CARRIED OUT EXCLUSIVELY BY AN AUTHORIZED INSTALLER

ALL OPERATIONS MUST BE CARRIED OUT IN ABSENCE OF POWER SUPPLY

PART FOR BOTH INSTALLER AND END-USER

GENERAL NOTICE

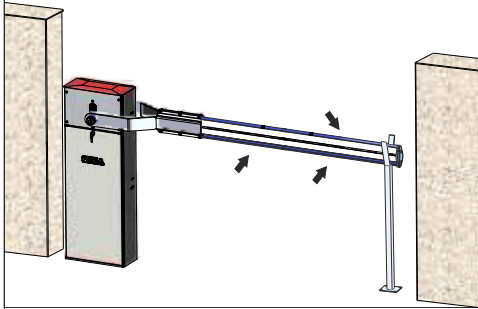

RISK EXAMINATION: The points pointed by arrows are potentially dangerous. The installer must take a thorough risk examination to prevent crushing, conveying, cutting, grappling, trapping so as to guarantee a safe installation for people, things and animals (Re. Laws in force in the Country where installation has been made). As for misunderstandings that may arise refer to your area distributor or call our help desk. These instructions are part of the device and must be kept in a well known place. The installer shall follow the provided instructions thoroughly. SEA products must only be used to automate doors, gates and wings. Any initiative taken without SEA explicit authorization will preserve the manufacturer from whatsoever respon-

sibility. The installer shall provide warning notices on not assessable further risks. SEA in its relentless aim to improve the products, is allowed to make whatsoever adjustment without giving notice. This doesn't oblige SEA to upgrade the past production. SEA can not be deemed responsible for any damage or accident caused by product breaking, being damages or accidents due to a failure to comply with the instructions herein. The guarantee will be void and the manufacturer responsibility will be nullified if SEA original spare parts are not being used. The electrical installation shall be carried out by a professional technician who will release documentation as requested by the laws in force. Packaging materials such as plastic bags, foam polystyrene, nails etc must be kept out of children's reach as dangers may arise.

INITIAL TEST AND STARTING OF THE AUTOMATION: After having completed the necessary operations for a correct installation of the product and after having evaluated all the risks which could arise in any installation, **it is necessary to test the automation to guarantee the maximum safety and to guarantee that the Laws in force are fully respected.** The first Start must be executed according to the rule **EN 12445** which establishes the methods of tests for checking the gate automation respecting the limits established by the rule **EN 12453**

SAFETY PRECAUTIONS: All electrical works should comply with the current regulations. A 16A/0,030 differential switch must be used. Separate the source cables (operators, power supply) and command cables (photocells, push-buttons, etc). Be sure the entire system is properly grounded. Always run cables in separate ducts to prevent interferences

INTENDED USE: The operator has been designed to be used as access automatic barrier only

SPARE PARTS: Send request for spare parts to: **SEA S.p.A. - Teramo - ITALY - www.seateam.com**

SAFETY AND ENVIRONMENTAL COMPATIBILITY: Don't waste product packing materials and/or circuits

STORAGE: T = -30°C/+60°C ; Humidity = min. 5% / max. 90% (without condensation); Materials must be properly packaged, handled with care and with appropriate vehicles

WARRANTY LIMITS - see the sales conditions

MAINTENANCE AND DECOMMISSION: must only be carried out by specialized and authorized personnel

THE MANUFACTURER CAN NOT BE DEEMED RESPONSIBLE FOR ANY DAMAGE OR INJURY CAUSED BY IMPROPER USE OF THIS PRODUCT

SEA S.p.A. reserves the right to make any required modification or change to the products and/or to this manual without any advanced notice obligation.

1. Read carefully these instructions before beginning to install the product. Store these instructions for future reference
2. Don't waste product packaging materials and/or circuits
3. This product was designed and built strictly for the use indicated in this documentation. Any other use, not expressly indicated here, could compromise the good condition/operation of the product and/or be a source of danger. SEAS.p.A. declines all liability caused by improper use or different use in respect to the intended one.
4. The mechanical parts must comply with Directives: Machine Regulation 2006/42/CE and following adjustments, Low Tension (2006/95/CE), Electromagnetic Consistency (2004/108/CE); Installation must respect Directives: EN12453 and EN12445.
5. Do not install the equipment in an explosive atmosphere.
6. SEA is not responsible for failure to observe Good Techniques in the construction of the locking elements to motorize or for any deformation that may occur during use
7. Before attempting any job on the system, cut out electrical power and disconnect the batteries. Be sure that the grounding system is perfectly constructed, and connect to it the metal parts of the gate
8. Use of the indicator-light is recommended for every system, as well as a warning sign well-fixed to the frame structure.
9. SEA declines all liability concerning the automated system safety and efficiency, if components used are not produced by SEA
10. For maintenance, strictly use original parts by SEA.
11. Do not modify in any way the components of the automated system.
12. The installer shall supply all information concerning the system manual functioning in case of emergency and shall hand over to the user the warnings handbook supplied with the product.
13. Do not allow children or adults to stay near the product while it is operating. The application cannot be used by children, by people with reduced physical, mental or sensorial capacity or by people without experience or necessary training. Keep remote controls or other pulse generators away from children, to prevent involuntary activation of the system.
14. Transit through the leaves is allowed only when the gate is fully open.
15. The User must not attempt to repair or to take direct action on the system and must solely contact qualified SEA personnel or SEA service centers. The User can apply only the manual function of emergency.
16. The power cables maximum length between the central engine and motors should not be greater than 10 m. Use cables with 2,5 mm² section. Use double insulation cable (cable sheath) to the immediate vicinity of the terminals, in particular for the 230V cable. Keep an adequate distance (at least 2.5 mm in air), between the conductors in low voltage (230V) and the conductors in safety low voltage (SELV) or use an appropriate sheath that provides extra insulation having a thickness of 1 mm



SEA®



Automatic Gate Openers

International registered trademark n. 804888

SEA S.p.A.

Zona Industriale Sant'Atto - 64100 - Teramo - ITALY

Tel. +39 0 861 588341 r.a. Fax +39 0 861 588344

www.seateam.com