



SEA[®]



Automatic Gate Openers

International registered trademark n. 804888

COMPACT

UNDERGROUND HYDRAULIC OPERATOR FOR SWING GATES



SEA S.p.A.

Zona industriale Sant'Atto - 64020 Teramo - (ITALY)

Tel. +39 0861 588341 r.a. Fax +39 0861 588344

www.seateam.com

seacom@seateam.com

TECHNICAL SPECIFICATIONS

The **COMPACT** consists of a hydraulic power unit and a hydraulic jack contained in a **cataphoresis treated foundation box** (*stainless steel on request*). The **hydraulic unit casing** is used as an oil tank and contains the electric motor, the fluid pump, the distributor and the hydraulic oil. The wheeling unit is composed by a double piston connected to a rack which engages with the pinion of the leaf dragging shaft.

The operator is available with an **adjustable hydraulic slowdown** (*optional*) operating in the two «stop» phases of the leaf (*the slowdown starts from the last 15° of leaf rotation*)

It is advisable to use operators equipped with the hydraulic locking system which guarantees a perfect sealing **on gates with leaves up to 2m length**. For gates with **leaves over 2m length**, it is advisable to **use operators without hydraulic lock but with electric lock** that ensures a perfect sealing. In case of power failure, the system is equipped with a **release that allows the gate to be opened manually**

MAIN COMPONENTS

- 1 Braking regulation screw (if provided)
- 2 Emergency release (authorized staff only)
- 3 By-pass regulation
- 4 Exit hole for electric cables
- 5 Filling oil cap
- 6 Water draining hole
- 7 Oil level indicator
- 8 Draining screw
- 9 Greaser
- 10 Rod support

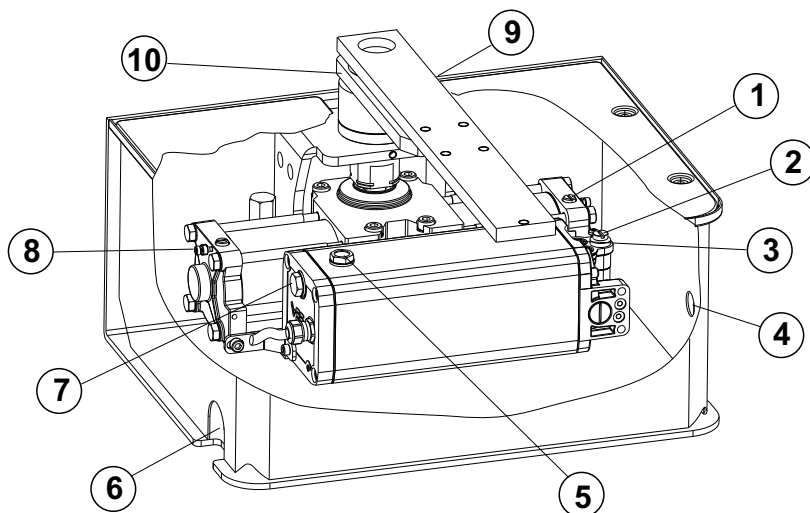

Fig. 1

DIMENSIONS (mm)

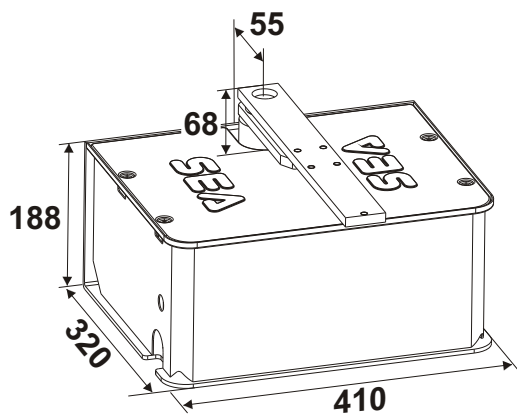

Fig. 2

USING GRAPHIC

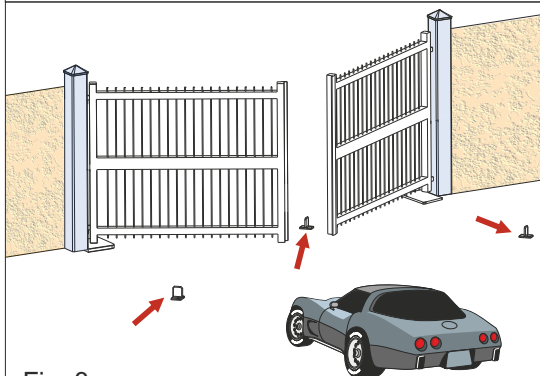
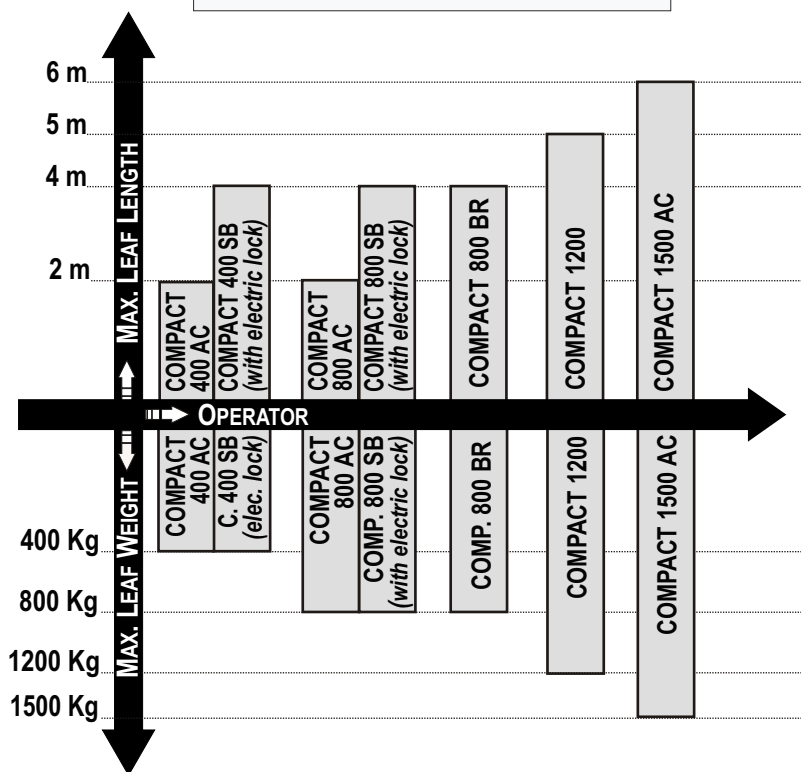

Fig. 3

! IT IS ALWAYS NECESSARY TO INSTALL THE MECHANICAL STOPS BOTH IN OPENING AND CLOSING

TECHNICAL FEATURES

| TECHNICAL DATA | COMPACT 400 | COMPACT 800 | COMPACT 800 BR 36V |
|----------------------------|-----------------------------------|-------------|--------------------|
| POWER SUPPLY | 230V~ ± 5% - 50/60 Hz | | |
| MOTOR POWER SUPPLY | 230V | | 36 V |
| MOTOR POWER | 220 W | | 260 W |
| ABSORBED CURRENT | 1,1 A | | --- |
| MOTOR ROTATION SPEED | 1400 rpm | | 2300 rpm |
| ANGULAR SPEED | 7°/sec | | MAX. 9°/sec. |
| CYCLES HOUR (WITH T 20°C)* | 45 | | 60 |
| MAX. WORKING PRESSURE | 50 bar | | 60 bar |
| OPERATING TEMPERATURE | - 20° C ↯ + 55° C ↯ | | |
| THERMAL PROTECTION | 130° C | | --- |
| MAX TORQUE | 56 daNm | | 60daNm |
| STARTING CAPACITOR | 12,5 µF | | --- |
| PUMP CAPACITY | 0,5 L | | 0,5 L |
| HYDRAULIC SLOWDOWN | SI 15° AP/CH (IF PROVIDED) | | ELECTRONIC |
| OPERATOR WEIGHT | 13 Kg | 13,8 Kg | |
| PROTECTION CLASS | IP 67 | | |
| MAX. LEAF WEIGHT | 400 Kg | 800 Kg | |
| MAX. LEAF LENGTH | 3 m | 4 m | |
| BRAKING REGULATION | ON CONTROL UNIT OR ON OPERATOR ** | | |

* THE INDICATED FREQUENCY OF USE IS VALID ONLY FOR THE FIRST OPERATING HOUR AND AT A 20°C TEMPERATURE

** IN CASE OF OPERATOR WITH HYDRAULIC SLOW-DOWN (OPTIONAL)

| TECHNICAL DATA | COMPACT 1200 (120V) | COMPACT 1200 (230V) | COMPACT 1500 |
|----------------------------|-----------------------------------|-----------------------|--------------|
| POWER SUPPLY | 120V~ ± 5% - 50/60 Hz | 230V~ ± 5% - 50/60 Hz | |
| MOTOR POWER SUPPLY | 120V | 230V | |
| MOTOR POWER | 220 W | 310 W | 330 W |
| ABSORBED CURRENT | 2,45 A | 1,5 A | 1,6 A |
| MOTOR ROTATION SPEED | 1530 rpm | 1400 rpm | |
| ANGULAR SPEED | 11°/sec | 8,2°/sec | |
| CYCLES HOUR (WITH T 20°C)* | 60 | | |
| MAX. WORKING PRESSURE | 50 bar | | |
| OPERATING TEMPERATURE | - 20° C ↯ + 55° C ↯ | | |
| THERMAL PROTECTION | 130° C | | |
| MAX TORQUE | 75 daNm | | 82 daNm |
| STARTING CAPACITOR | 60 µF | 10 µF | |
| PUMP CAPACITY | 1,5 L | | |
| HYDRAULIC SLOWDOWN | SI 15° AP/CH (IF PROVIDED) | | |
| OPERATOR WEIGHT | 15 Kg | | |
| PROTECTION CLASS | IP 67 | | |
| MAX. LEAF WEIGHT | 1200 Kg | | 1500 Kg |
| MAX. LEAF LENGTH | 5 m | | 6 m |
| BRAKING REGULATION | ON CONTROL UNIT OR ON OPERATOR ** | | |

* THE INDICATED FREQUENCY OF USE IS VALID ONLY FOR THE FIRST OPERATING HOUR AND AT A 20°C TEMPERATURE

** IN CASE OF OPERATOR WITH HYDRAULIC SLOW-DOWN (OPTIONAL)

INSTALLATION

1. GATE ARRANGEMENTS

Before the installation, check that all gate parts (fixed and mobile) have a resistant and non-deformable structure; also make the following checks:

- a) the leaves must be rigid and compact;
- b) that the weight and length of each leaf do not exceed the values supported by the specific operator model (see tables);
- c) that the hinges and the structure of the gate operate smoothly throughout the execution of the movement, without frictions or obstacles

ONLY THE UPPER HINGE IS SUFFICIENT TO INSTALL THE OPERATOR;

- d) *The installation of the mechanical stops in opening and closing is always necessary (Fig. 3)*

2. INSTALLATION OF THE FOUNDATION CARRYING BOX

To install the foundation box:

- 2.1. Based on the measurements shown in Fig. 4, prepare an excavation inside which the foundation box will be cemented

⚠ IT IS MANDATORY TO RESPECT THE MINIMUM DISTANCE OF THE ROTATION AXIS FROM THE PILLAR - 55 mm

- 2.2. Provide a **PVC DRAIN PIPE OF 40 MM Ø AT LEAST FOR THE DRAINAGE OF RAINWATER**, to be inserted in the slot inside the box before it is cemented (Fig. 5); **BRING THE PIPE TO THE DRAIN OF THE SEWER LINE**

- 2.3. Provide a **FLEXIBLE PLASTIC SHEATH OF 20 MM Ø AT LEAST FOR THE PASSAGE OF THE ELECTRICAL CABLES**, to be inserted in the slot inside the box before it is cemented (Fig. 5); **BRING THE SHEATH UP TO THE JUNCTION BOX**

- 2.4. Before cementing the foundation box, make sure that it is perfectly horizontal and perpendicular to the axis of the gate, using a level (Fig. 6)

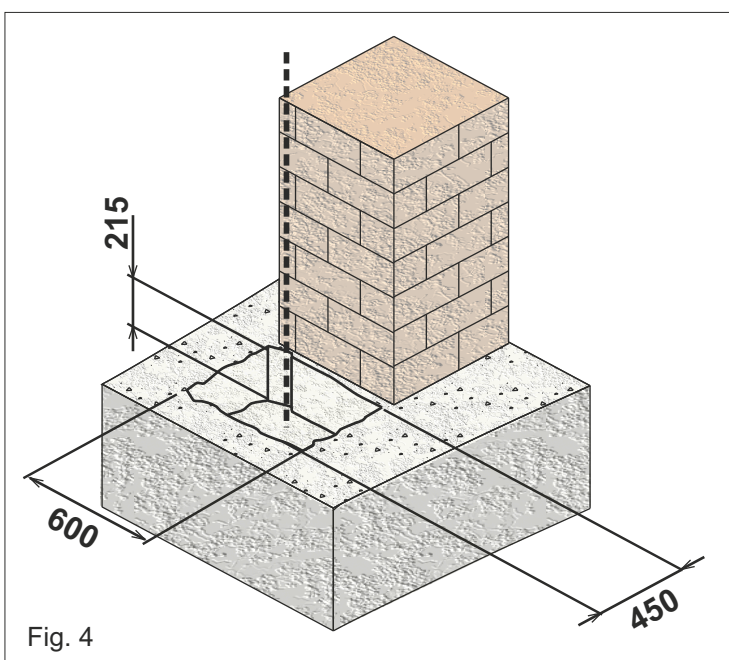

Fig. 4

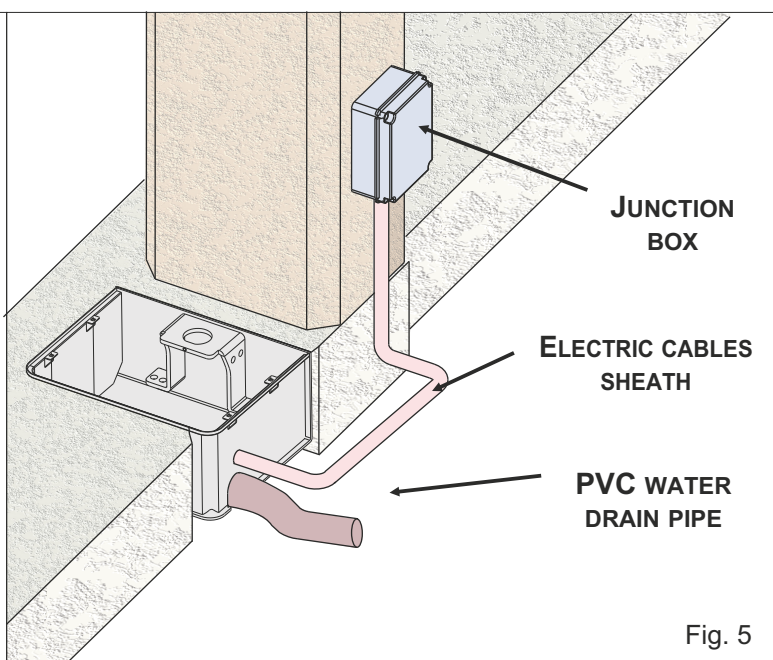
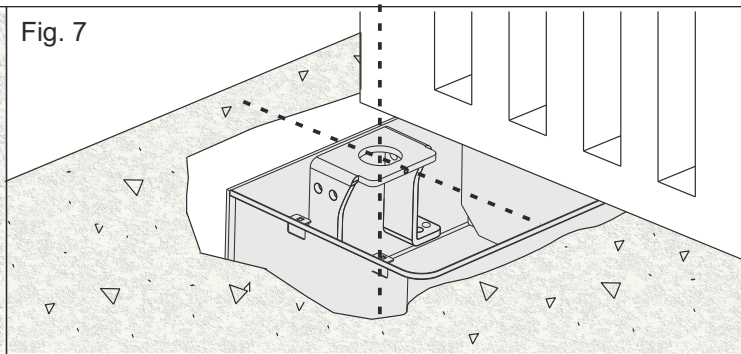
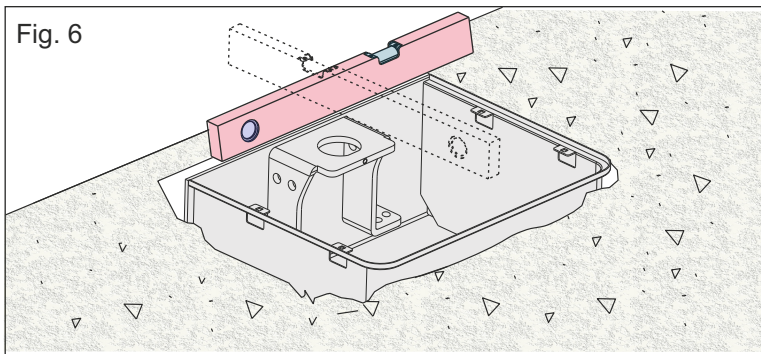

Fig. 5



3. ASSEMBLY OF THE LEAF SUPPORTING

⚠ THE AXIS OF THE UPPER HINGE OF THE GATE MUST COINCIDE WITH THE AXIS OF THE BOX SHAFT (FIG. 7);

3.1. Insert the sliding bushing into the box and secure it with the appropriate screw «A» (Fig. 8)

3.2. Insert all assemblies as shown in Fig. 8

⚠ WARNING! BEFORE ASSEMBLY, LUBRICATE ALL COMPONENTS WITH THE SUPPLIED GREASE

Fig. 8

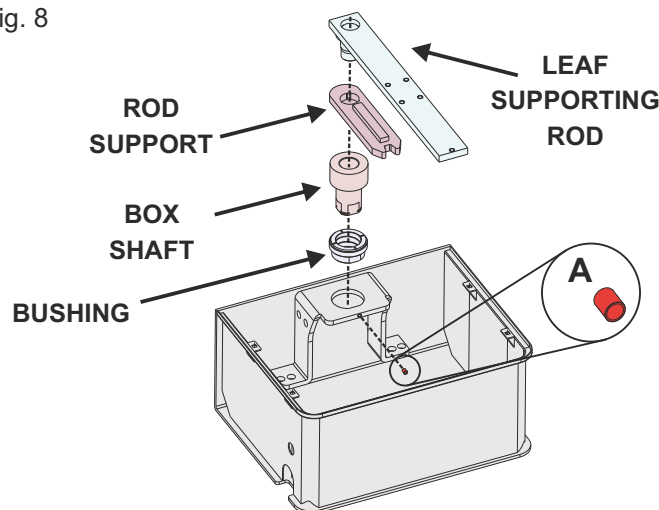

4. MOUNTING OF THE LEAF ON THE SUPPORT ROD

⚠ BEFORE INSTALLING THE LEAF ON THE FOUNDATION BOX, MAKE SURE THAT THE CONCRETE INSIDE THE EXCAVATION IS PERFECTLY SOLIDIFIED

4.1. Place the gate leaf on the support rod, taking care to make the rotation axis of the leaf hinge coincide with the rotation axis of the support; be sure to respect the perpendicularity with the rotation axis (Fig. 9 - Fig. 10)

4.2. Carefully weld the support rod to the leaf, making fixing sections of about 3 or 4 cm along the contact surface and avoiding welding near the threaded holes (Fig. 11)

Fig. 9

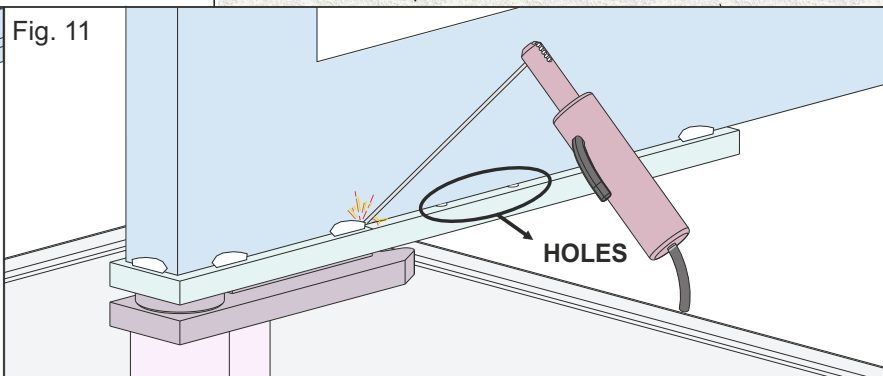
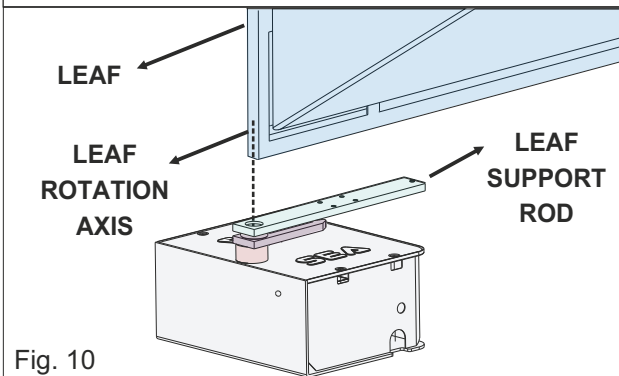
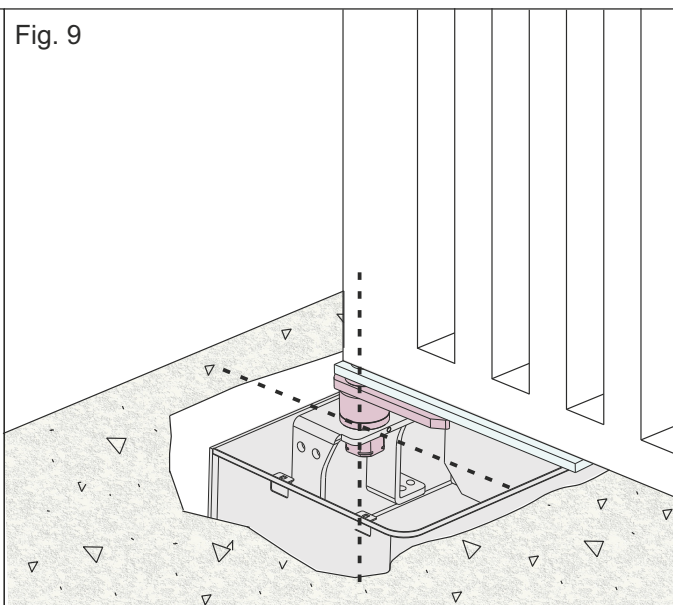

Fig. 10

Fig. 11

⚠ DO NOT PLACE THE LEAF OUTSIDE THE AXES (FIG. 12 - 13); MAKE THE SHAFT COINCIDE WITH THE ROTATION AXIS OF THE LEAF HINGE, CONSIDERING THAT THE MINIMUM DISTANCE FROM THE COLUMN MUST BE 55 mm (FIG. 14) GREASE EVERYTHING BY THE USE OF THE SPECIAL GREASE NIPPLE, UNTIL THE GREASE COMES OUT FROM BOTH SIDES

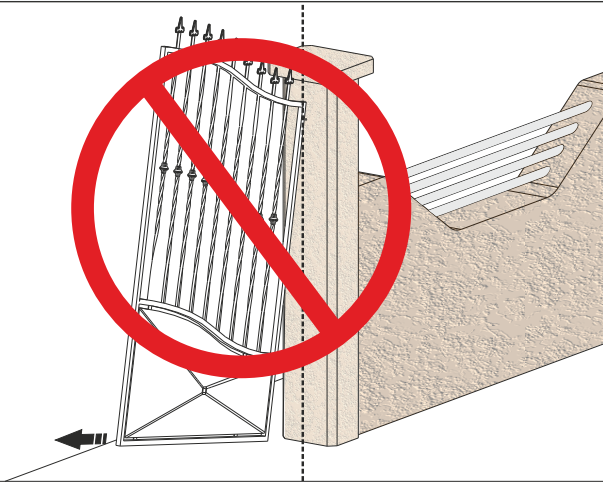

Fig. 12

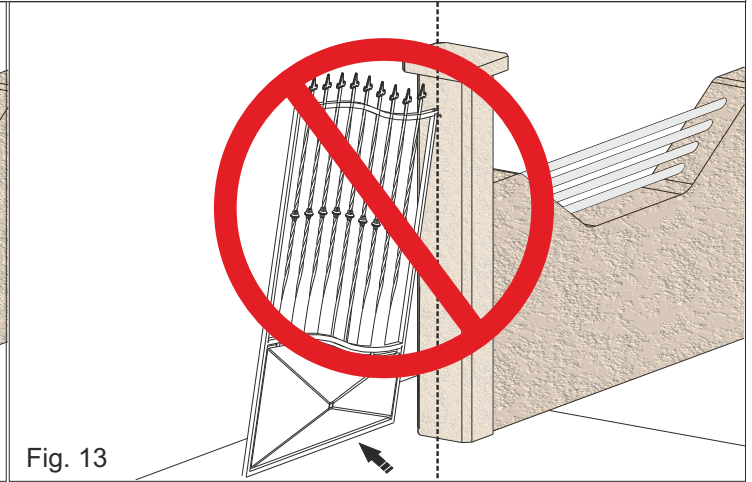

Fig. 13

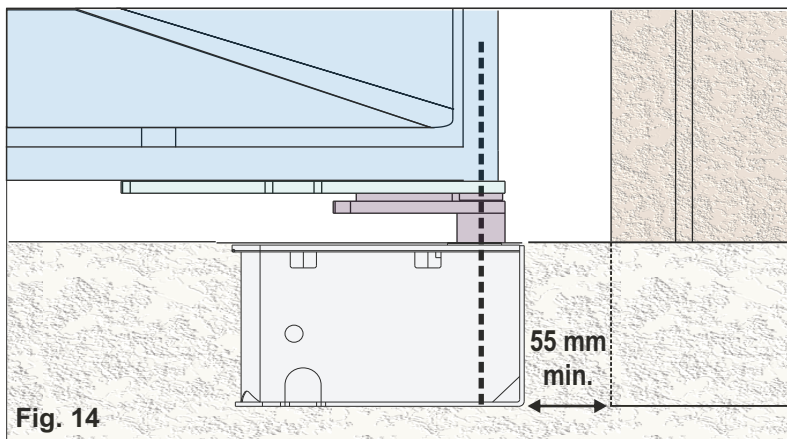

Fig. 14

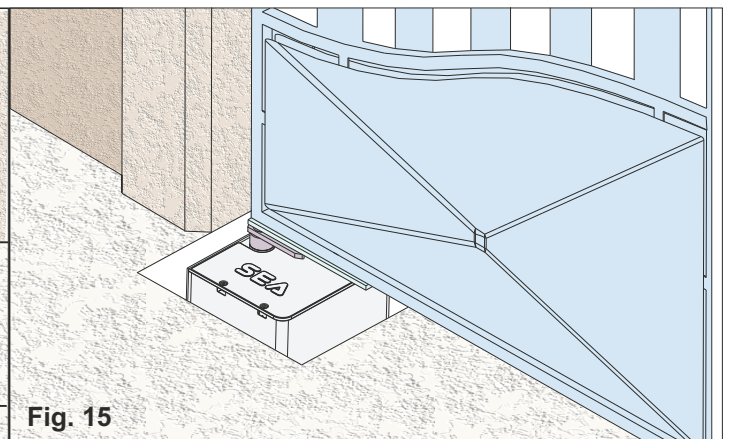

Fig. 15

5. INSTALLATION OF THE OPERATOR INSIDE THE BOX

**MAKE SURE TO MOUNT THE OPERATOR IN THE CORRECT POSITION;
REFER TO THE FOLLOWING DRAWINGS TO EXECUTE THE CORRECT OPERATOR POSITIONING SEQUENCE**

5.1. Position the operator in correspondence with the supporting box and insert it vertically, making sure it is positioned in the correct direction, as shown in Fig. 16

5.2. Once the operator has been placed in the box, move it forward (Fig. 17) until the splined shaft of the operator is in correspondence with the hole of the box shaft

5.3. Lift the operator and insert its shaft inside the box shaft (Fig. 18)

5.4. Secure the operator by acting on the screws «1» and «2» as shown in Fig. 19

⚠ IT IS ADVISABLE TO WELD THE ROD SUPPORT AND THE BOX SHAFT (FIG. 21) AFTER INSTALLING THE OPERATOR INSIDE THE BOX, IN ORDER TO TAKE ADVANTAGE OF ALL THE AVAILABLE STROKE AND, FOR VERSIONS WITH HYDRAULIC SLOWDOWN, TO SIMPLIFY THE REACHING OF THE DESIRED SLOWDOWN STARTING POINT

BEFORE WELDING THE TWO COMPONENTS, BE CAREFUL THAT ONE OF THE SHAFT PLANES COINCIDES WITH ONE SIDE OF THE ROD SUPPORT (SEE FIG. 20) TO ENSURE THE MAXIMUM ANGLE WHEN THE «MECHANICAL STOP KIT» IS INSTALLED

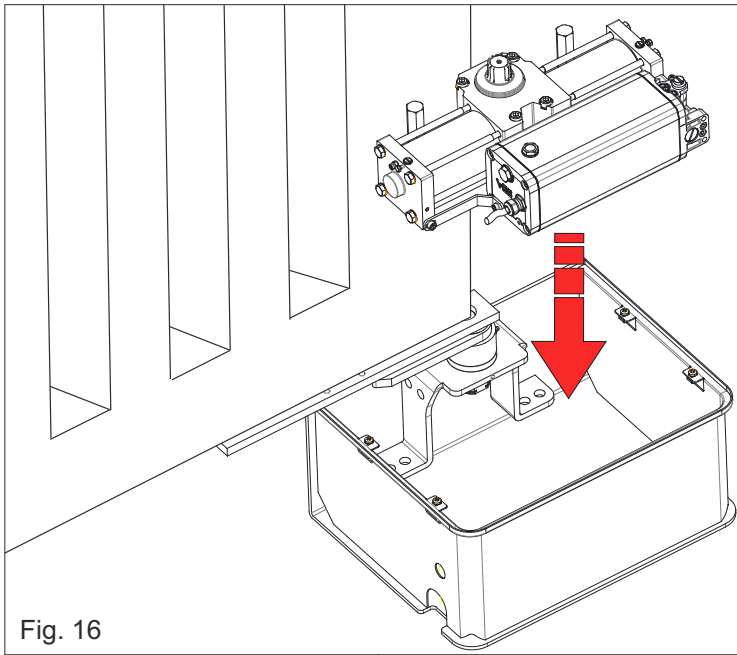

Fig. 16

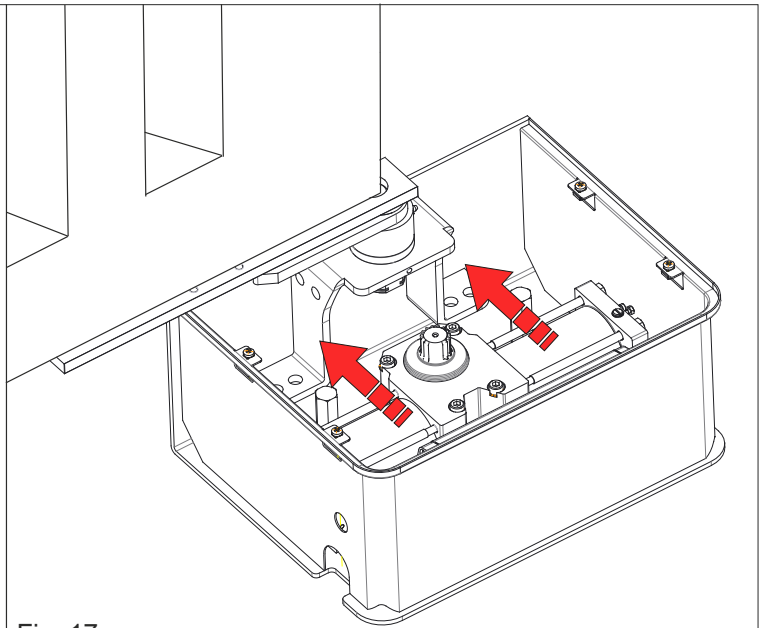

Fig. 17

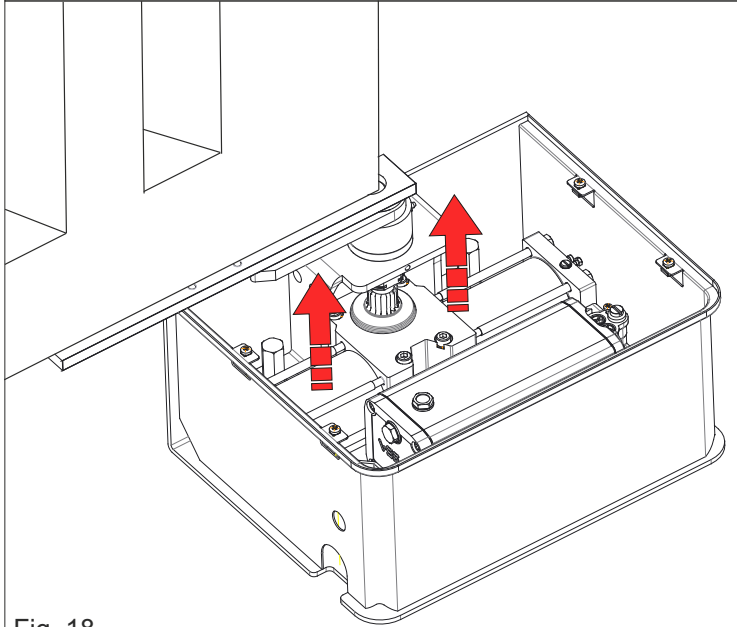

Fig. 18

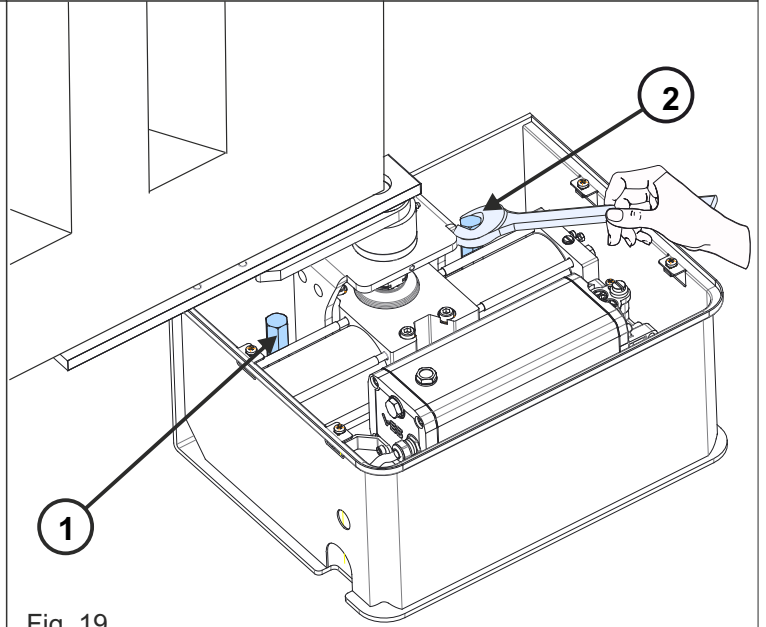

Fig. 19

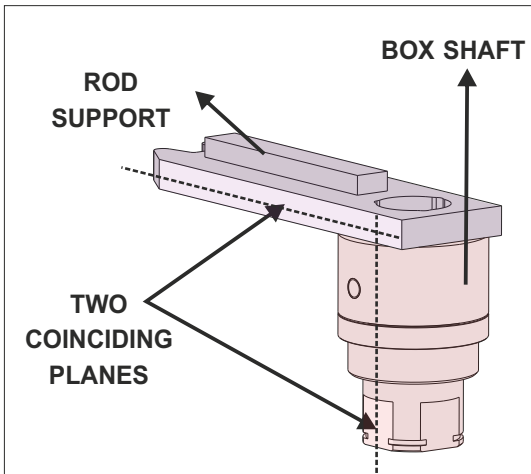

Fig. 20

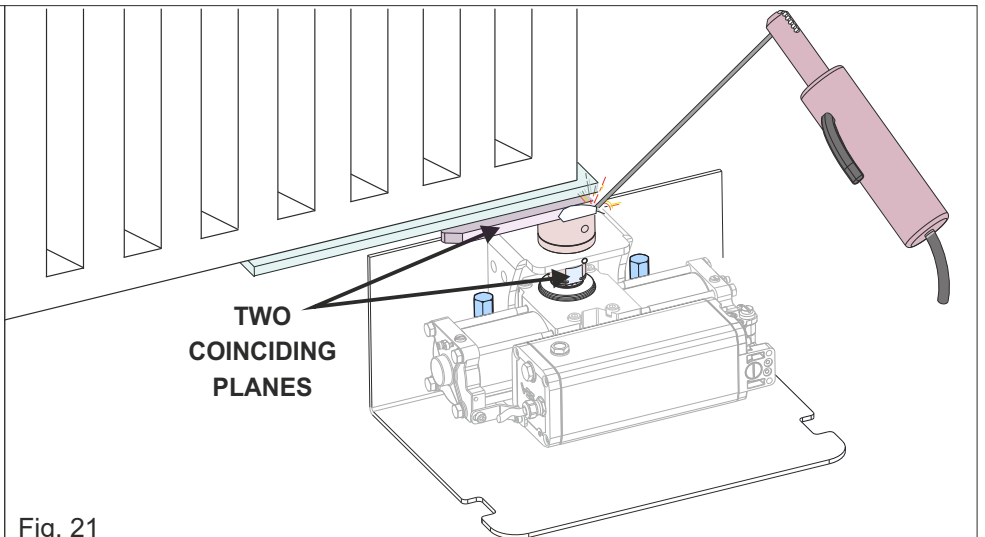

Fig. 21

⚠ WELD ONLY AT THE TIME OF INSTALLATION (IN CASE THE OPERATOR IS INSTALLED LATER)

6. ADJUSTABLE MECHANICAL STOP KIT INSTALLATION (OPTIONAL ACCESSORY)

▲ THE MECHANICAL STOPS CANNOT BE INSTALLED ON THE «COMPACT 1500» MODEL

6.1. Insert the stop bracket into the box shaft, **making sure it is oriented in the same direction of the leaf support bracket**, then lock it with the seeger (Fig. 22 e Fig. 23)

6.2. Fix the two stop supports «A» to the box using the provided screws «B» and their fixing bolts

6.3. Insert the two «stop screws» «C» into the special housings on the stop supports, using the bolts «D» as shown in (Fig. 24 e Fig. 25)

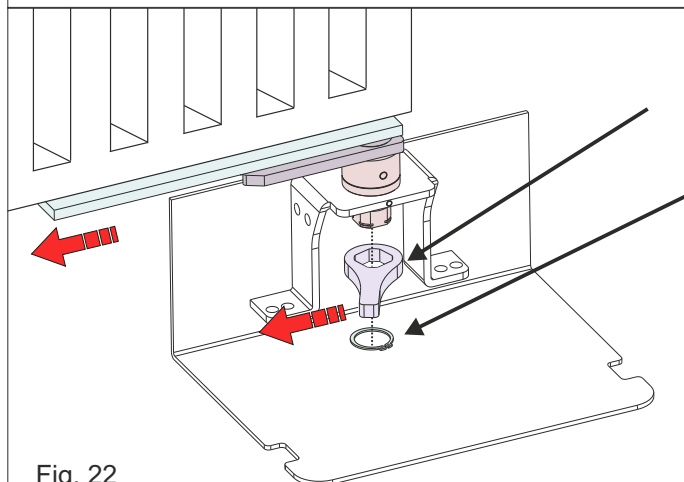

Fig. 22

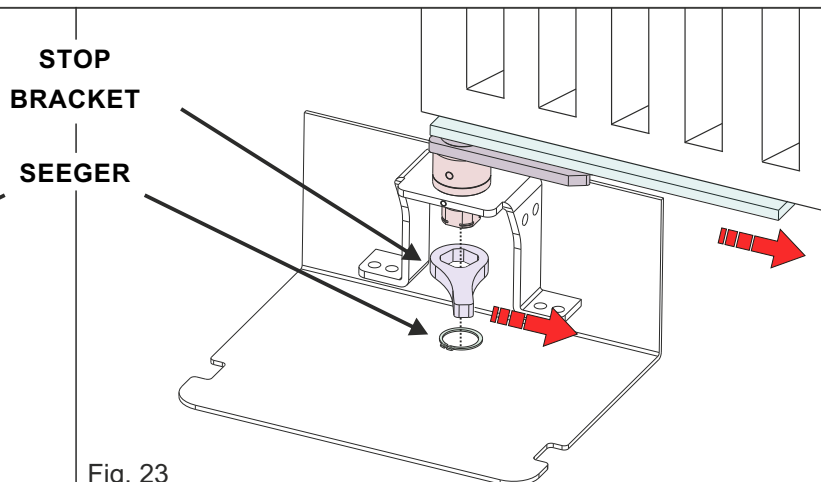

Fig. 23

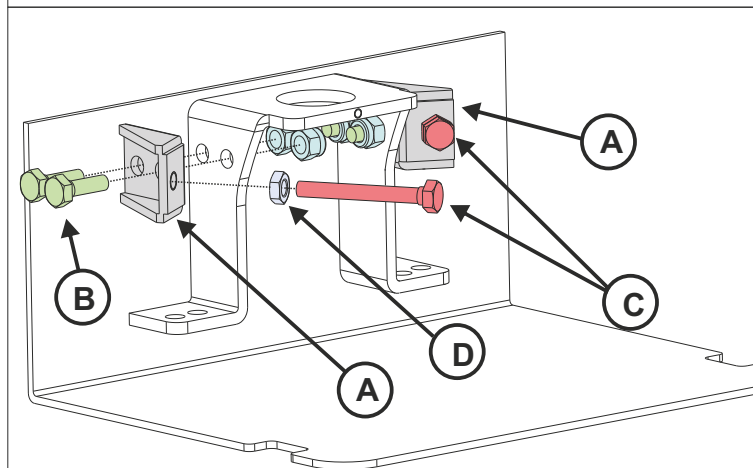

Fig. 24

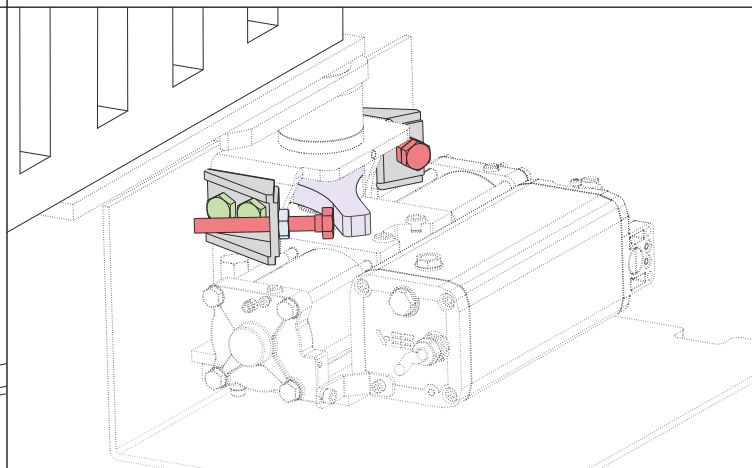
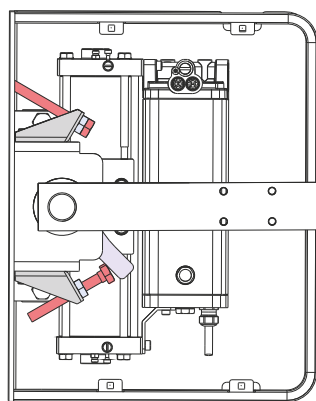
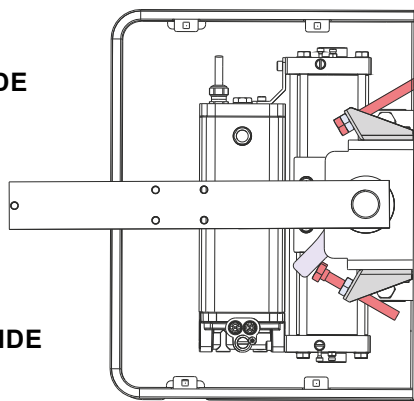

Fig. 25

LEFT OPERATOR



RIGHT OPERATOR



INSIDE

OUTSIDE

Fig. 26

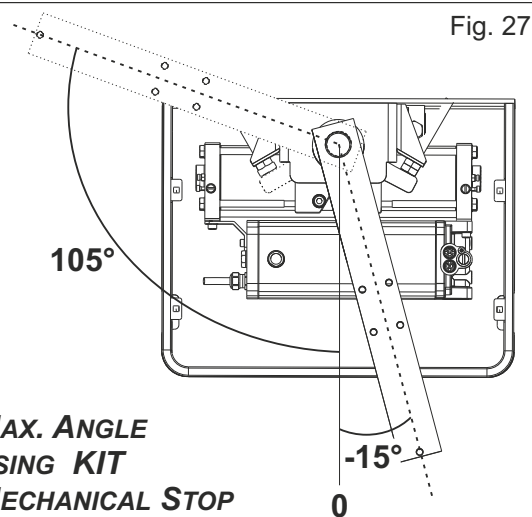

Fig. 27

MAX. ANGLE
USING KIT
MECHANICAL STOP

0

7. ADJUSTMENT OF THE THRUST FORCE

⚠ CARRY OUT THE CALIBRATION WITH RUNNING MOTOR !

The thrust force or anti-crushing force must be evaluated manually (better with a dynamometer) in both directions of rotation. To adjust the thrust force:

7.1. Adjust the by-pass valves (Fig. 28) using the appropriate key «A» (**supplied to authorized installers**), turning it clockwise to increase the force, counter-clockwise to decrease the force; The correspondence of the valves with the respective adjustment depends on the opening direction of the operator: opening towards the left or opening towards the right (Fig. 29 or Fig. 30);

The calibration through by-pass valves only adjusts the thrust force, it does not adjust the speed of the leaf!

7.2. Once the thrust force has been adjusted, **it is important to adjust the operating time via electronic control unit**; the operating time must be set from 2 to 4 seconds higher than the complete maneuver time.

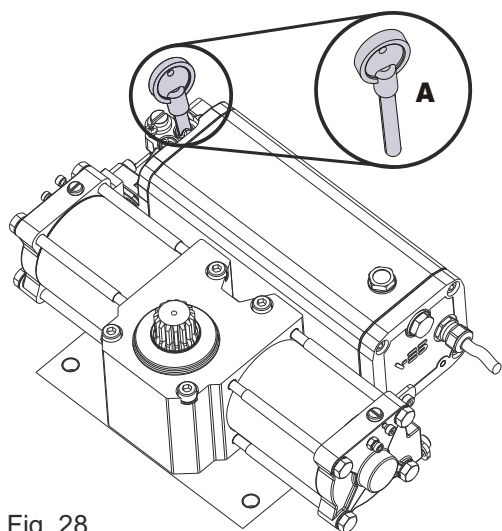
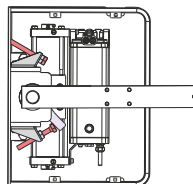

Fig. 28

LEFT OPENING OPERATOR:



BY-PASS VALVES

Fig. 29

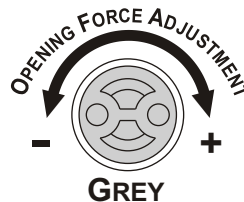

GREY



YELLOW

RIGHT OPENING OPERATOR:

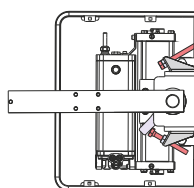

BY-PASS VALVES

Fig. 30

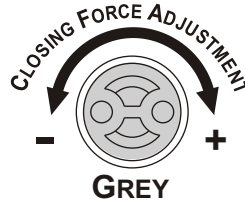

GREY



YELLOW

⚠ ADJUST THE GATE OPENING AND CLOSING FORCE IN ORDER TO RESPECT THE FORCE DIAGRAM AS PER EN12453; HOWEVER, THE THRUST FORCE MUST NEVER EXCEED 15 KgF

THE VALVES MUST BE ADJUSTED IN PARALLEL WITHOUT DIFFERENCES OF CALIBRATION BETWEEN THE TWO VALVES (OPENING AND CLOSING VALVES). E.G. : IF THE GRAY VALVE IS ADJUSTED BY HALF A TURN, THEN THE YELLOW VALVE MUST BE ADJUSTED IN THE SAME WAY

8. BRAKING ADJUSTMENT (ONLY FOR OPERATORS EQUIPPED WITH HYDRAULIC BRAKE)

⚠ THE SLOWDOWN STARTS FROM THE LAST 15° DEGREES OF THE LEAF ROTATION!

It is possible to adjust the leaf slowdown on opening and closing, by the use of the braking adjustment screw:

8.1. Loosen the Allen screw «1» which locks the brake adjustment screw «2» (Fig. 31) and adjust it **CLOCKWISE FOR A GREATER BRAKING (SPEED REDUCTION) OR ANTI-CLOCKWISE FOR LESS BRAKING (SPEED INCREASE)**

8.2. At the end of the adjustment, tighten the Allen screw «1» to re-lock the braking adjustment screw «2»

Fig. 31

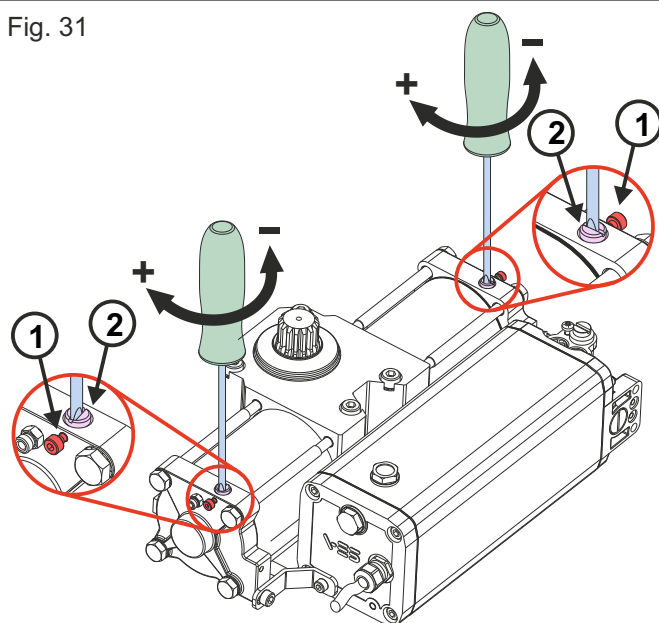

9. RELEASE SYSTEM

THE OPERATOR IS EQUIPPED WITH AN INTERNAL RELEASE SYSTEM, WHICH CAN BE ACCESSED BY LIFTING THE BOX COVER AND ACTING ON THE SCREW «A» THROUGH A SCREWDRIVER (FIG. 32)

9.1. TO RELEASE: Using a screwdriver, turn the release screw «A» anti-clockwise for about 180° as shown in Fig. 32

9.2. TO LOCK: Using a screwdriver, turn the release screw «A» clockwise until it stops, as shown in Fig. 32

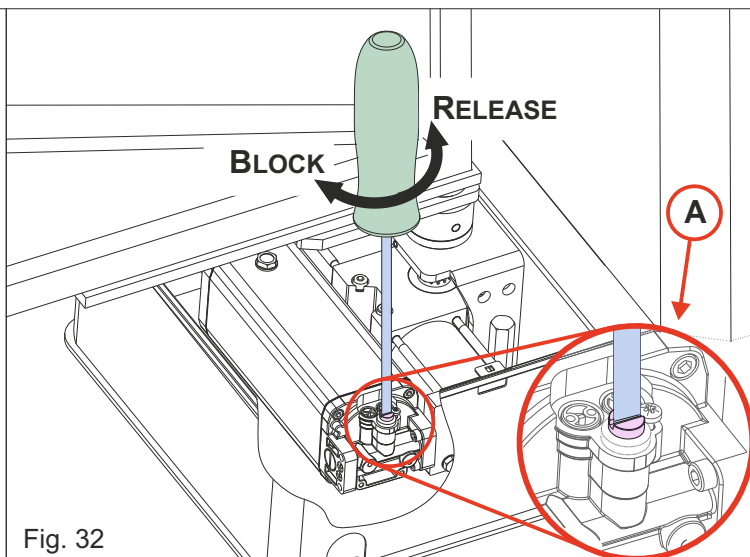

Fig. 32

6. RELEASE MOUNTING - BASIC RELEASE / PLUS RELEASE

For COMPACT operators there are two types of release:

BASIC RELEASE (WITH CUSTOMIZED KEY) OR PLUS RELEASE (WITH DIN KEY)

6.1. BASIC RELEASE: grease the coupling pin «A» and mount the release system under the leaf support rod using the 4 supplied screws (Fig. 33a)

6.2. PLUS RELEASE: grease the coupling pin «A» and mount the release system under the leaf support rod using the 5 supplied screws (Fig. 34a)

FOR THE ELECTRICAL CONNECTIONS OF THE RELEASE, REFER TO THE ELECTRONIC CONTROL UNIT USER MANUAL

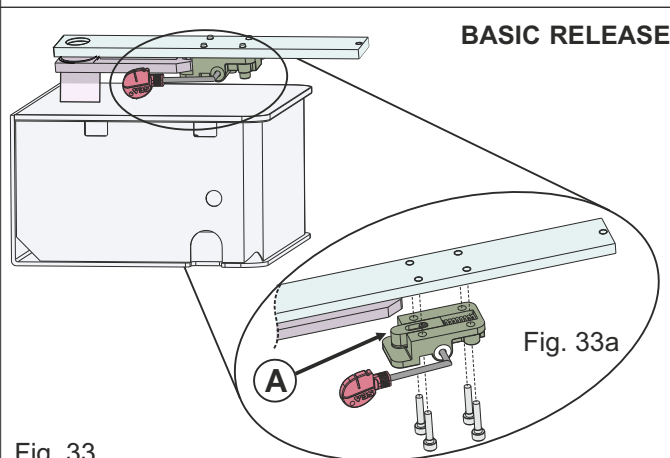

Fig. 33

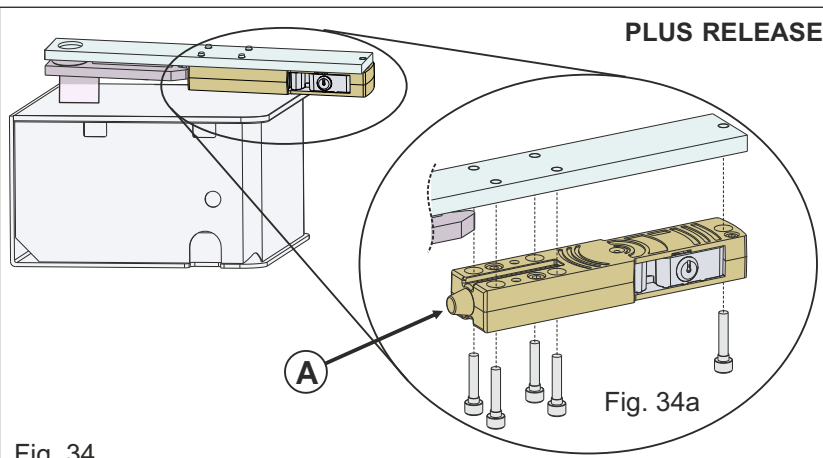

Fig. 34

11. OPERATOR COMMISSIONING

BEFORE STARTING THE OPERATOR, IT IS IMPERATIVE TO GREASE THE CASE THROUGH THE SPECIAL GREASE NIPPLE, (FIG. 35) UNTIL THE GREASE COMES OUT. USE GREASE DIN 51502 KP 2 N-20 - K 2 K-20

11.1. Once all installation and adjustment operations have been completed, carry out some **slow** manual maneuvers, checking there is no friction, irregularity and that the movement is flowing along the complete stroke of the gate

IN ORDER TO PERFORM THIS OPERATION, THE OPERATOR MUST BE UNLOCKED; FOLLOW THE «UNLOCK / LOCK» INSTRUCTIONS IN CHAPTER 13

11.2. Refer to the wiring diagrams on the control unit manual for electrical connections

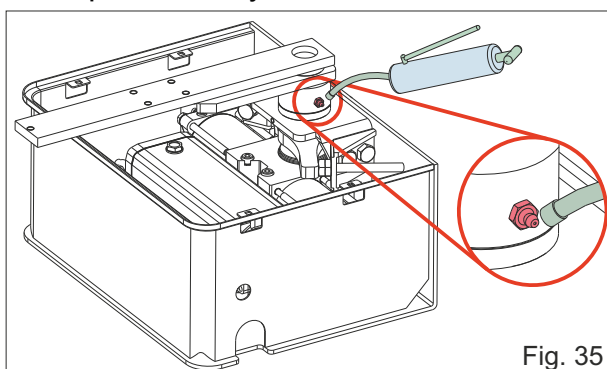

Fig. 35

12. COMPACT 800 36V BRUSHLESS

12.1. The **COMPACT 800 BR** operator contains *some different components than the other COMPACT models*.

Different components are indicated with an asterisk (*) in the drawing aside (Fig. 36); In any case, the assembly method is similar to that of their counterparts in the other operator models;

For assembly refer to the instructions in **chapter 6**, making sure to mount the stop bracket and the magnet in the correct direction (*in the same direction in which the leaf support bracket is oriented*). See Fig. 22 and Fig 23

12.2. The **COMPACT 800 BR** can be managed through the **UNIGATE BR** control unit; The motor must be connected to the **BR MODULE** according to the connection diagram in Fig. 38.

The opening and closing limit switches must be both connected to the **CN2 terminal of the UNILOGIC MODULE** (Fig. 39).

CAUTION! the black cable of the opening limit switch must be connected to the **clamp 14**, while the black cable of the closing limit switch must be connected to the **clamp 15**

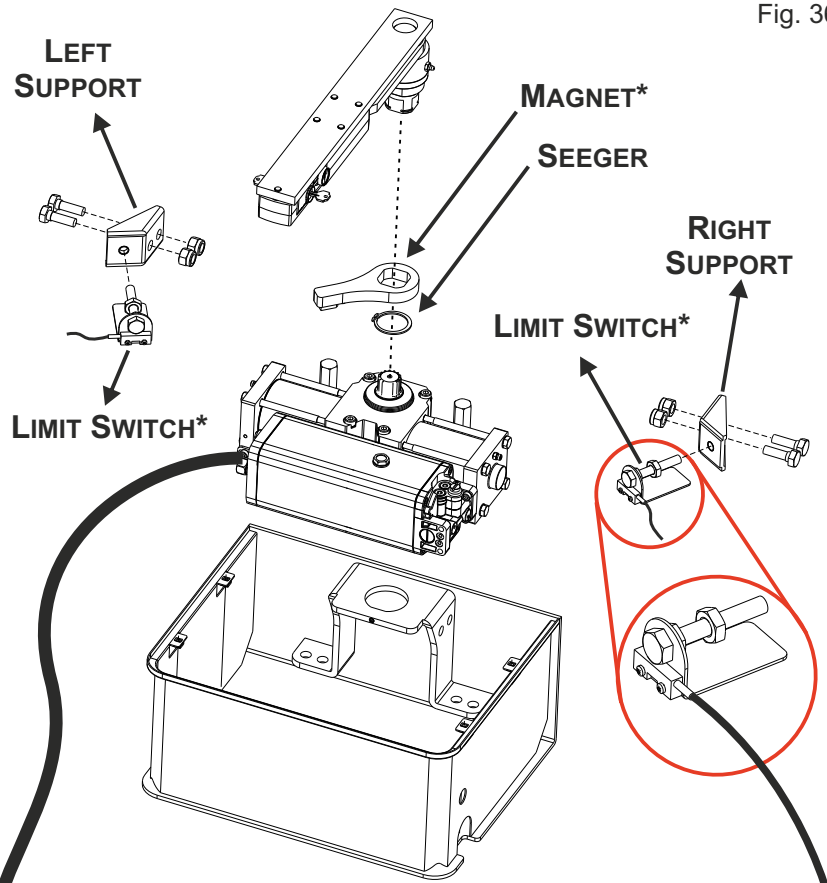

Fig. 36

COMPACT 800 36V BRUSHLESS

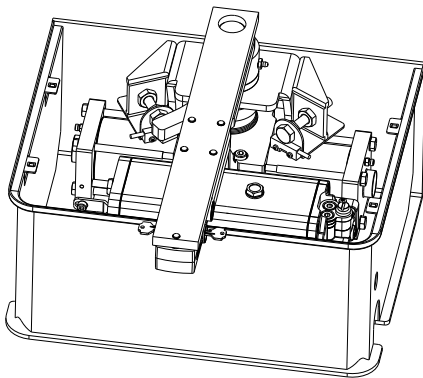
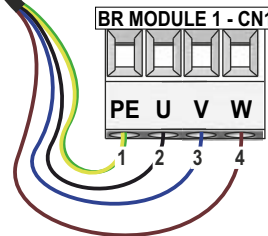

Fig. 37

COMPACT 800 BR CONNECTION



- 1 = GREEN/YELLOW
- 2 = BLACK
- 3 = BLUE
- 4 = BROWN

Fig. 38

EXAMPLE OF CONNECTION OF A LIMIT SWITCH

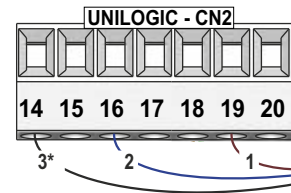

- 1 = BROWN (+ 24V)
- 2 = BLUE (-)
- 3 = BLACK (N.C.) *OR ON CLAMP 15

- 14 = OPENING LIMIT SWITCH (N.C.)
- 15 = CLOSING LIMIT SWITCH (N.C.)
- 16 = COMMON (COM)
- 19 = 24V (+)

Fig. 39

PART FOR BOTH INSTALLER AND END-USER



ALL THE UNLOCKING AND LOCKING OPERATIONS AND ALL THE PERIODIC MAINTENANCE OPERATIONS MUST BE CARRIED OUT IN ABSENCE OF POWER SUPPLY

13. OPERATOR RELEASE

13.1. BASIC RELEASE

TO UNLOCK

- insert the supplied Allen key in the slot «A» and turn 180° towards the center of the gate (Fig. 40)
- hold the key and move the leaf; once the desired leaf position has been reached, turn the key to its original position and remove it

TO LOCK

- move the leaf to its original position until the release system is re-hooked.

13.2. PLUS RELEASE

TO UNLOCK

- insert the supplied key into the lock and turn it 90 ° clockwise (Fig. 41)
- pull the key outwards up to its stop in order to extract the handle of the release system (Fig. 42)
- move the leaf to the desired position, close the handle of the release system and remove the key

TO LOCK

- move the leaf to its original position until the release system is re-hooked.

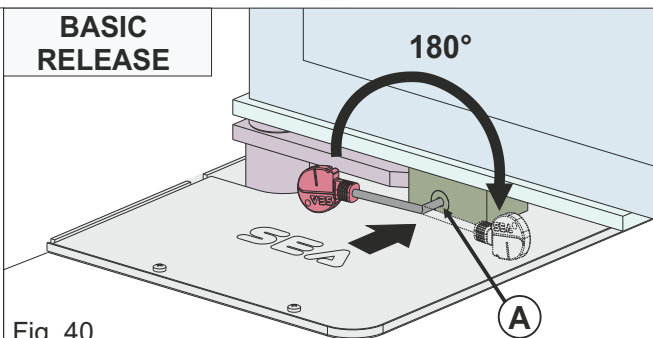

Fig. 40

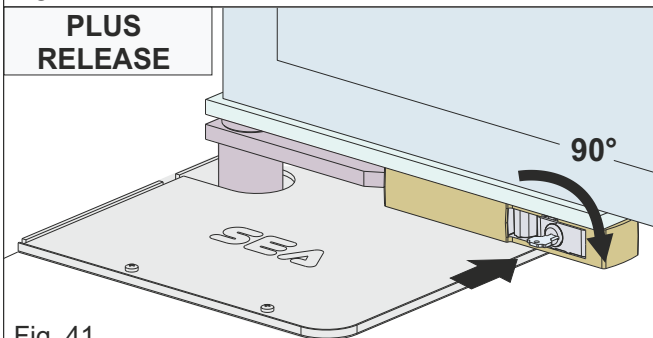

Fig. 41

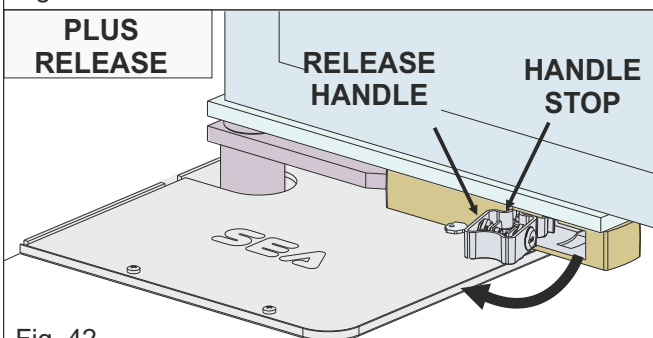

Fig. 42

14. STANDARD CONNECTION

- 1) Operators
- 2) Mechanical stops
- 3) Control unit
- 4) Flashing lamp
- 5) Right photocell
- 6) 16A - 0,03A differential switch
- 7) Left photocell
- 8) «START/STOP» key-button
- 9) Antenna
- 10) Photocell columns
- 11) Warning notices

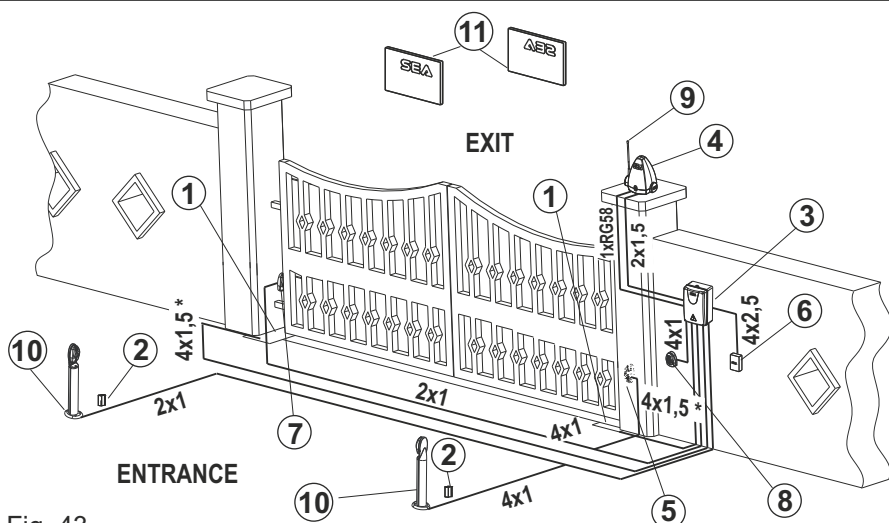

Fig. 43

PART FOR BOTH INSTALLER AND END-USER

PERIODIC MAINTENANCE

| | |
|--|---------|
| Check the oil level (transparent cap No. 7 in Fig. 1) | annual |
| Replace the oil | 4 years |
| Check the functionality of the by-pass valves (check the force in opening and closing) | annual |
| Check the functionality of the release system | annual |
| Check the slowdown system adjustment (if provided) | annual |
| Check the correct drainage of rainwater | annual |
| Check the integrity of the connection cables | annual |
| Grease all the moving parts | annual |
| Grease the rotation shaft of the box, as shown in Fig. 35 | annual |

⚠ ALL OPERATIONS MUST BE CARRIED OUT EXCLUSIVELY BY AN AUTHORIZED INSTALLER

RISK EXAMINATION: The points pointed by arrows are potentially dangerous. The installer must take a thorough risk examination to prevent crushing, conveying, cutting, grappling, trapping so as to guarantee a safe installation for people, things and animals (Re. Laws in force in the Country where installation has been made). As for misunderstandings that may arise refer to your area distributor or call our help desk. These instructions are part of the device and must be kept in a well known place. The installer shall follow the provided instructions thoroughly. SEA products must only be used to

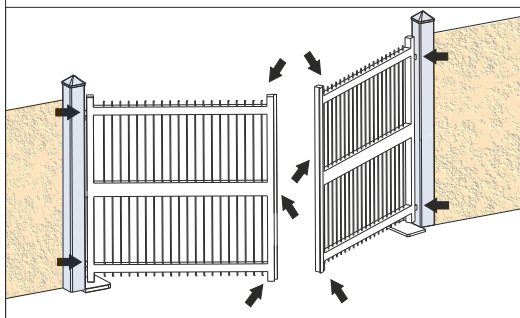

automate doors, gates and wings. Any initiative taken without SEA explicit authorization will preserve the manufacturer from whatsoever responsibility. The installer shall provide warning notices on not assessable further risks. SEA in its relentless aim to improve the products, is allowed to make whatsoever adjustment without giving notice. This doesn't oblige SEA to upgrade the past production. SEA can not be deemed responsible for any damage or accident caused by product breaking, being damages or accidents due to a failure to comply with the instructions herein. The guarantee will be void and the manufacturer responsibility will be nullified if SEA original spare parts are not being used. The electrical installation shall be carried out by a professional technician who will release documentation as requested by the

laws in force. Packaging materials such as plastic bags, foam polystyrene, nails etc must be kept out of children's reach as dangers may arise.

INITIAL TEST AND STARTING OF THE AUTOMATION: After having completed the necessary operations for a correct installation of the product and after having evaluated all the risks which could arise in any installation, **it is necessary to test the automation to guarantee the maximum security and, in particular, to guarantee that the laws in force are fully respected.** The first Start must be executed according to the rule **EN 12445** which establishes the methods of tests for checking the gate automation respecting the limits established by the rule **EN 12453**

SAFETY PRECAUTIONS: All electrical work should comply with the current regulations. A 16A / 0,030 differential switch must be used. Separate the source cables (operators, power supply) and command cables (photocells, push-buttons, etc). Be sure the entire system is properly earth bonded. Always run cables in separate ducts to prevent interferences

INTENDED USE: The operator has been designed to be used for the automation of swing gates only

SPARE PARTS: Send request for spare parts to: **SEA S.p.A. - Teramo - ITALY - www.seateam.com**

SAFETY AND ENVIRONMENTAL COMPATIBILITY: Don't waste product packing materials and/or circuits

STORAGE: Materials must be properly packaged, handled with care and with appropriate vehicles

WARRANTY LIMITS - see the sales conditions

MAINTENANCE AND DECOMMISSION: must only be carried out by specialised and authorised personnel

THE MANUFACTURER CAN NOT BE DEEMED RESPONSIBLE FOR ANY DAMAGE OR INJURY CAUSED BY IMPROPER USE OF THIS PRODUCT

SEA S.p.A. reserves the right to make any required modification or change to the products and/or to this manual without any advanced notice obligation.

STORAGE TEMPERATURE

| T _{min} | T _{max} | Humidity _{min} | Humidity _{max} |
|------------------|------------------|-------------------------|--------------------------|
| -30°C ↓ | +60°C ↓ | 5% without condensation | 90% without condensation |

GENERAL NOTICE FOR THE INSTALLER AND THE USER

1. Read carefully these **Instructions** before beginning to install the product. Store these instructions for future reference
2. Don't waste product packaging materials and /or circuits.
3. This product was designed and built strictly for the use indicated in this documentation. Any other use, not expressly indicated here, could compromise the good condition/operation of the product and/or be a source of danger. SEA S.p.A. declines all liability caused by improper use or different use in respect to the intended one.
4. The mechanical parts must be comply with Directives: Machine Regulation 2006/42/CE and following adjustments), Low Tension (2006/95/CE), electromagnetic Consistency (2004/108/CE) Installation must be done respecting Directives: EN12453 and En12445.
5. Do not install the equipment in an explosive atmosphere.
6. SEA S.p.A. is not responsible for failure to observe Good Techniques in the construction of the locking elements to motorize, or for any deformation that may occur during use.
7. Before attempting any job on the system, cut out electrical power and disconnect the batteries. Be sure that the earthing system is perfectly constructed, and connect it metal parts of the lock.
8. Use of the indicator-light is recommended for every system, as well as a warning sign well-fixed to the frame structure.
9. SEA S.p.A. declines all liability as concerns the automated system's security and efficiency, if components used, are not produced by SEA
10. For maintenance, strictly use original parts by SEA.
11. Do not modify in any way the components of the automated system.
12. The installer shall supply all information concerning system's manual functioning in case of emergency, and shall hand over to the user the warnings handbook supplied with the product.
13. Do not allow children or adults to stay near the product while it is operating. The application cannot be used by children, by people with reduced physical, mental or sensorial capacity, or by people without experience or necessary training. Keep remote controls or other pulse generators away from children, to prevent involuntary activation of the system.
14. Transit through the leaves is allowed only when the gate is fully open.
15. The User must not attempt to repair or to take direct action on the system and must solely contact qualified SEA personnel or SEA service centers. User can apply only the manual function of emergency.
16. The power cables maximum length between the central engine and motors should not be greater than 10 m. Use cables with 2,5 mm² section. Use double insulation cable (cable sheath) to the immediate vicinity of the terminals, in particular for the 230V cable. Keep an adequate distance (at least 2.5 mm in air), between the conductors in low voltage (230V) and the conductors in low voltage safety (SELV) or use an appropriate sheath that provides extra insulation having a thickness of 1 mm.

TERMS OF SALES

EFFICACY OF THE FOLLOWING TERMS OF SALE: the following general terms of sale shall be applied to all orders sent to SEA S.p.A. All sales made by SEA to all costumers are made under the prescription of this terms of sales which are integral part of sale contract and cancel and substitute all apposed clauses or specific negotiations present in order document received from the buyer.

GENERAL NOTICE The systems must be assembled exclusively with SEA components, unless specific agreements apply. Non-compliance with the applicable safety standards (European Standards EM12453 – EM 12445) and with good installation practice releases SEA from any responsibilities. SEA shall not be held responsible for any failure to execute a correct and safe installation under the above mentioned standards.

1) PROPOSED ORDER The proposed order shall be accepted only prior SEA approval of it. By signing the proposed order, the Buyer shall be bound to enter a purchase agreement, according to the specifications stated in the proposed order.

On the other hand, failure to notify the Buyer of said approval must not be construed as automatic acceptance on the part of SEA.

2) PERIOD OF THE OFFER The offer proposed by SEA or by its branch sales department shall be valid for 30 solar days, unless otherwise notified.

3) PRICING The prices in the proposed order are quoted from the Price List which is valid on the date the order was issued. The discounts granted by the branch sales department of SEA shall apply only prior to acceptance on the part of SEA. The prices are for merchandise delivered ex-works from SEA establishment in Teramo, not including VAT and special packaging. SEA reserves the right to change at any time this price list, providing timely notice to the sales network. The special sales conditions with extra discount on quantity basis (Qx, Qx1, Qx2, Qx3 formula) is reserved to official distributors under SEA management written agreement

4) PAYMENTS The accepted forms of payment are each time notified or approved by SEA. The interest rate on delay in payment shall be 1.5% every month but anyway shall not be higher than the max. interest rate legally permitted.

5) DELIVERY Delivery shall take place, approximately and not peremptorily, within 30 working days from the date of receipt of the order, unless otherwise notified. Transport of the goods sold shall be at Buyer's cost and risk. SEA shall not bear the costs of delivery giving the goods to the carrier, as chosen either by SEA or by the Buyer. Any loss and/or damage of the goods during transport, are at Buyer's cost.

6) COMPLAINTS Any complaints or claims shall be sent to SEA within 8 solar days from receipt of the goods, proved by adequate supporting documents as to their truthfulness

7) SUPPLY The concerning order will be accepted by SEA without any engagement and subordinately to the possibility to get it's supplies of raw material which is necessary for the production; Eventual completely or partially unsuccessful executions cannot be reason for complains or reservations for damage. SEA supply is strictly limited to the goods of its manufacturing, not including assembly, installation and testing. SEA, therefore, disclaims any responsibility for damage deriving, also to third parties, from non-compliance of safety standards and good practice during installation and use of the purchased products.

8) WARRANTY The standard warranty period is 12 months. This warranty time can be extended by means of expedition of the warranty coupon as follows:

SILVER: The mechanical components of the operators belonging to this line are guaranteed for 24 months from the date of manufacturing written on the operator.

GOLD: The mechanical components of the operators belonging to this line are guaranteed for 36 months from the date of manufacturing written on the operator.

PLATINUM: The mechanical components of the operators belonging to this line are guaranteed for 36 months from the date of manufacturing written on the operator. The base warranty (36 months) will be extended for further 24 months (up to a total of 60 months) when it is acquired the certificate of warranty which will be filled in and sent to SEA S.p.A. The electronic devices and the systems of command are guaranteed for 24 months from the date of manufacturing. In case of defective product, SEA undertakes to replace free of charge or to repair the goods provided that they are returned to SEA repair centre. The definition of warranty status is by unquestionable assessment of SEA. The replaced parts shall remain propriety of SEA. Binding upon the parties, the material held in warranty by the Buyer, must be sent back to SEA repair centre with fees prepaid, and shall be dispatched by SEA with carriage forward. The warranty shall not cover any required labour activities

The recognized defects, whatever their nature, shall not produce any responsibility and/or damage claim on the part of the Buyer against SEA. The guarantee is in no case recognized if changes are made to the goods, or in the case of improper use, or in the case of tampering or improper assembly, or if the label affixed by the manufacturer has been removed including the SEA registered trademark No. 804888. Furthermore, the warranty shall not apply if SEA products are partly or completely coupled with non-original mechanical and/or electronic components, and in particular, without a specific relevant authorization, and if the Buyer is not making regular payments. The warranty shall not cover damage caused by transport, expendable material, faults due to non-conformity with performance specifications of the products shown in the price list. No indemnification is granted during repairing and/or replacing of the goods in warranty. SEA disclaims any responsibility for damage to objects and persons deriving from non-compliance with safety standards, installation instructions or use of sold goods. The repair of products under warranty and out of warranty is subject to compliance with the procedures notified by SEA.

9) RESERVED DOMAIN A clause of reserved domain applies to the sold goods; SEA shall decide autonomously whether to make use of it or not, whereby the Buyer purchases propriety of the goods only after full payment of the latter.

10) COMPETENT COURT OF LAW In case of disputes arising from the application of the agreement, the competent court of law is the tribunal of Teramo. SEA reserves the faculty to make technical changes to improve its own products, which are not in this price list at any moment and without notice. SEA declines any responsibility due to possible mistakes contained inside the present price list caused by printing and/or copying. The present price list cancels and substitutes the previous ones. The Buyer, according to the law No. 196/2003 (privacy code) consents to put his personal data, deriving from the present contract, in SEA archives and electronic files, and he also gives his consent to their treatment for commercial and administrative purposes.

Industrial ownership rights: once the Buyer has recognized that SEA has the exclusive legal ownership of the registered SEA brand num.804888 affixed on product labels and / or on manuals and / or on any other documentation, he will commit himself to use it in a way which does not reduce the value of these rights, he won't also remove, replace or modify brands or any other particularity from the products. Any kind of replication or use of SEA brand is forbidden as well as of any particularity on the products, unless preventive and expressed authorization by SEA.

In accomplishment with art. 1341 of the Italian Civil Law it will be approved expressly clauses under numbers:

4) PAYMENTS - 8) GUARANTEE - 10) COMPETENT COURT OF LAW

DECLARATION OF CONFORMITY DICHIARAZIONE DI CONFORMITÀ

SEA S.p.A. declares under its proper responsibility and, if applicable, under the responsibility of its authorised representative that, by installing the appropriate safety equipment and noise filtering, the products:

SEA S.p.A. dichiara sotto la propria responsabilità e, se applicabile, del suo rappresentante autorizzato che, con l'installazione degli adeguati dispositivi di sicurezza e di filtraggio disturbi, i prodotti:

| DESCRIPTION - DESCRIZIONE | MODEL - MODELLO | TRADEMARK - MARCA |
|---|-----------------|-------------------|
| COMPACT 400 AC 140° (AND ALL ITS BY-PRODUCTS - E TUTTI I SUOI DERIVATI) | 12112105 | SEA |
| COMPACT 400 SB 140° (AND ALL ITS BY-PRODUCTS - E TUTTI I SUOI DERIVATI) | 12112110 | SEA |
| COMPACT 800 AC 140° (AND ALL ITS BY-PRODUCTS - E TUTTI I SUOI DERIVATI) | 12121020 | SEA |
| COMPACT 800 SB 140° (AND ALL ITS BY-PRODUCTS - E TUTTI I SUOI DERIVATI) | 12121015 | SEA |
| COMPACT 800 AC BR 110° (AND ALL ITS BY-PRODUCTS - E TUTTI I SUOI DERIVATI) | 12123120 | SEA |
| SUPER COMPACT 1200 AC (AND ALL ITS BY-PRODUCTS - E TUTTI I SUOI DERIVATI) | 12130005 | SEA |
| SUPER COMPACT 1200 SB (AND ALL ITS BY-PRODUCTS - E TUTTI I SUOI DERIVATI) | 12130505 | SEA |
| SUPER COMPACT 1500 AC (AND ALL ITS BY-PRODUCTS - E TUTTI I SUOI DERIVATI) | 12130005IV | SEA |
| SUPER COMPACT 1500 SB (AND ALL ITS BY-PRODUCTS - E TUTTI I SUOI DERIVATI) | 12130505IV | SEA |

are built to be integrated into a machine or to be assembled with other machinery to create a machine under the provisions of Directive 2006/42/CE

sono costruiti per essere incorporati in una macchina o per essere assemblati con altri macchinari per costruire una macchina ai sensi della Direttiva 2006/42/CE

are conforming to the essential safety requirements related to the products within the field of applicability of the Community Directives 2014/35/UE and 2014/30/UE

sono conformi ai requisiti essenziali di sicurezza relativi ai prodotti entro il campo di applicabilità delle Direttive Comunitarie 2014/35/UE e 2014/30/UE

THE MANUFACTURER OR THE AUTHORIZED REPRESENTATIVE
IL COSTRUTTORE O IL RAPPRESENTATE AUTORIZZATO

SEA S.p.A.

ZONA INDUSTRIALE SANT'ATTO

64100 - TERAMO - ITALY

+ 39 0 861 588341

www.seateam.com

PLACE AND DATE OF ISSUE

LUOGO E DATA DI EMISSIONE

TERAMO, 28/07/2021

L'Administratore

The Administrator

Ernio Di Spurio





Automatic Gate Openers

International registered trademark n. 804888

SEA S.p.A.

Zona industriale 64020 S.ATTO Teramo - (ITALY)

Tel. +39 0861 588341 r.a. Fax +39 0861 588344

www.seateam.com

seacom@seateam.com