



SEA[®]

Sistemi Elettronici
di Apertura Porte e Cancelli
International registered trademark n. 804888

CE

English

VERG 24V

Electro-mechanical barrier

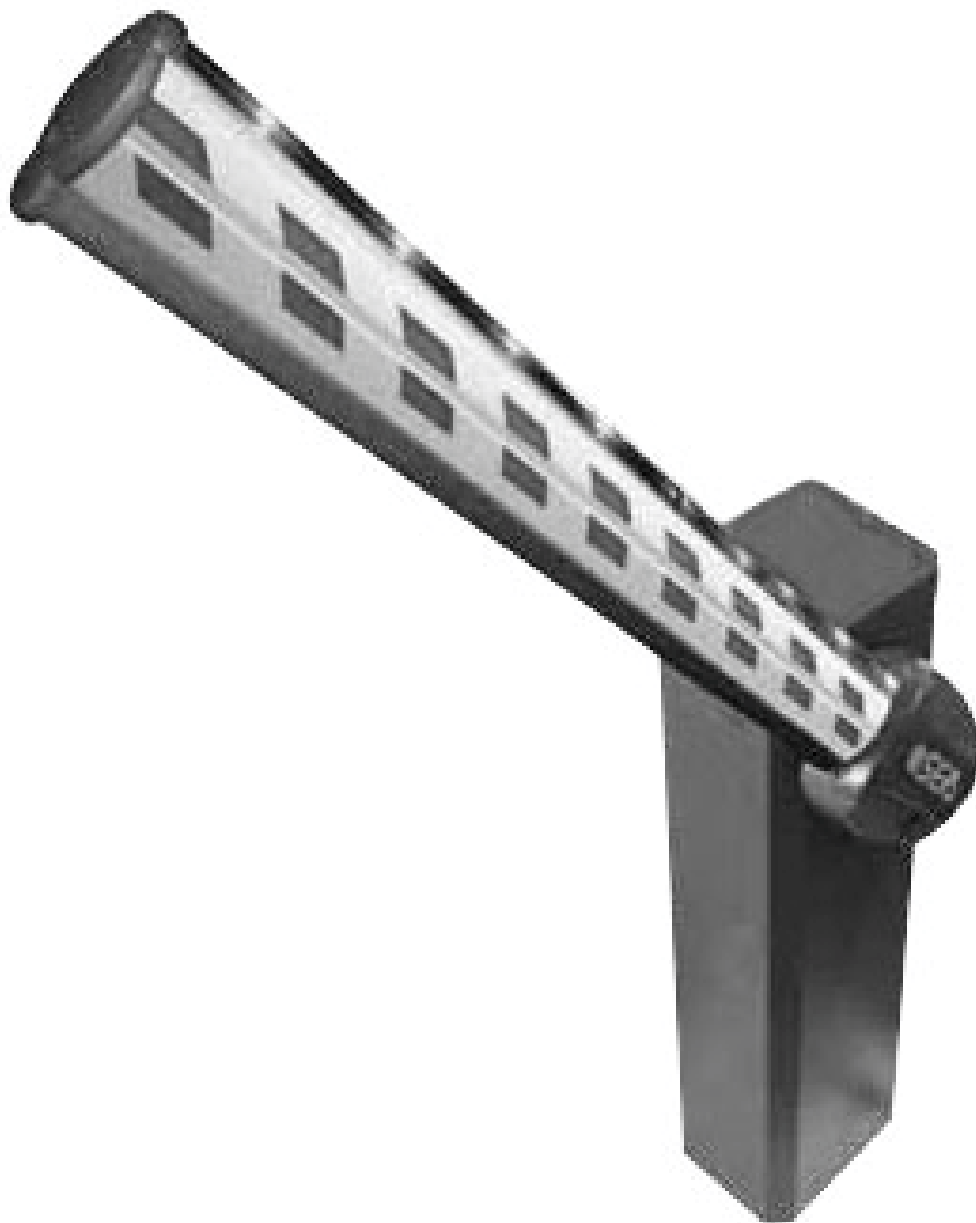

SEA S.p.A.
Zona Ind.le S. Atto - 64020 S. Nicolò a Tordino (TE)
Tel. +39 0861.588341 - Fax +39 0861.588344

www.seateam.com
e-mail: seacom@seateam.com

VERG 24V BARRIER

General features

VERG 24V is an electro-mechanical barrier (2, 3, 4, 5 and 6 metres) with Encoder recommended for the automation of access points which require a high opening/closing speed (parking lots, motorways, airports, etc.) and frequent use

features. The automation includes an anti-crush security system with adjustable sensitivity, which guarantees a barrier force value not exceeding 15 kg, thus protecting people and objects from any accidents. A highly reliable slowdown device guarantees the total control of the forces of inertia. The emergency batteries guaranty at least 15 opening cycles (depending on the installed accessories) in case of power failure and a release system allows the manual opening in case of emergency.

The automation system is composed of the following elements:

- 1 Adjustable mechanical stop
- 2 Manual release with key
- 3 Galvanised steel rocker arm.
- 4 VERG 24V, casing cover with lock and DIN key
- 5 Balancing spring.
- 6 Electronic control unit.
- 7 Foundation plate out of galvanized steel
- 8 Emergency batteries 2x12V 2Ah.
- 9 24V⁼⁼⁼ - 2400 rpm electric motor
- 10 Reduction gear
- 11 Cataphoresis-treated and polyester painted VERG 24V casing, for outside, protects all included mechanical and electronic devices from fire, flood, lightning, etc. . **Stainless steel casing available on request.**
- 12 Battery charger circuit

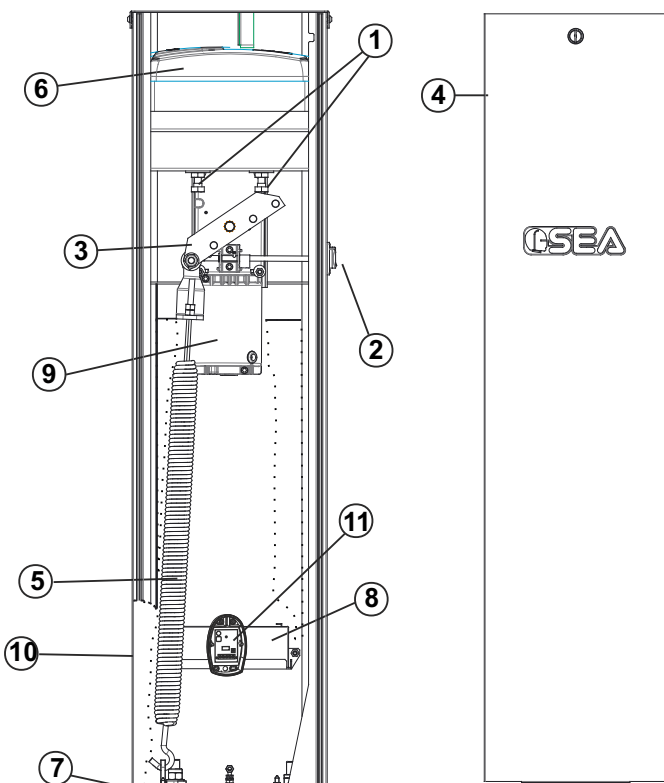
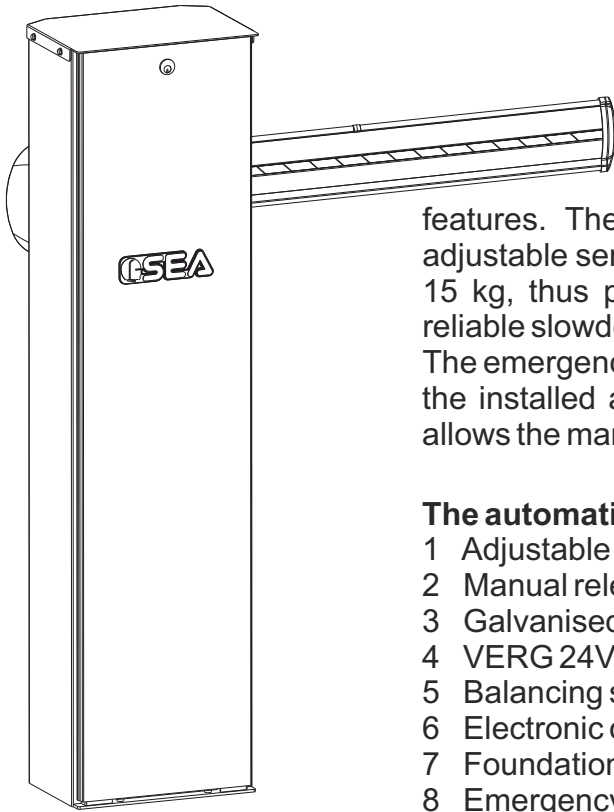

Main components:

- 1) Adjustable mechanical stop
- 2) Manual release system
- 3) Rocker arm
- 4) VERG 24V casing cover
- 5) Balancing spring
- 6) Electronic control unit
- 7) VERG anchoring plate (optional)
- 8) Emergency batteries 2x12V 2Ah (optional)
- 9) 24V⁼⁼⁼ Gearmotor with Encoder
- 10) VERG casing
- 11) Battery charger circuit (optional with battery kit)

TECHNICAL FEATURES	VERG 230V	VERG 115V
Supply voltage	230 V~ ± 5% - 50/60 Hz	115 V~ ± 5% - 50/60 Hz
Motor power supply	24Vdc	
Motor power	60 W	
Motor speed	2400 RPM	
Working temperature	-20°K + 55°C	
Opening/closing time	Adjustable	
Protection class	IP55	
Manual release system	Yes	
Usage frequency	60%	
Anti-crushing device	Ammeter	
Holding block	Yes	
Slowdown	Electronic	
Barrier body treatment	Cataphoresis treated and polyester painted	
Weight	39 kg	
Electronic equipment	USER 1 24V	
Encoder	yes	yes

Note: The frequency of use is valid only for the first hour at 20°C room temperature.

OVERALL DIMENSIONS:

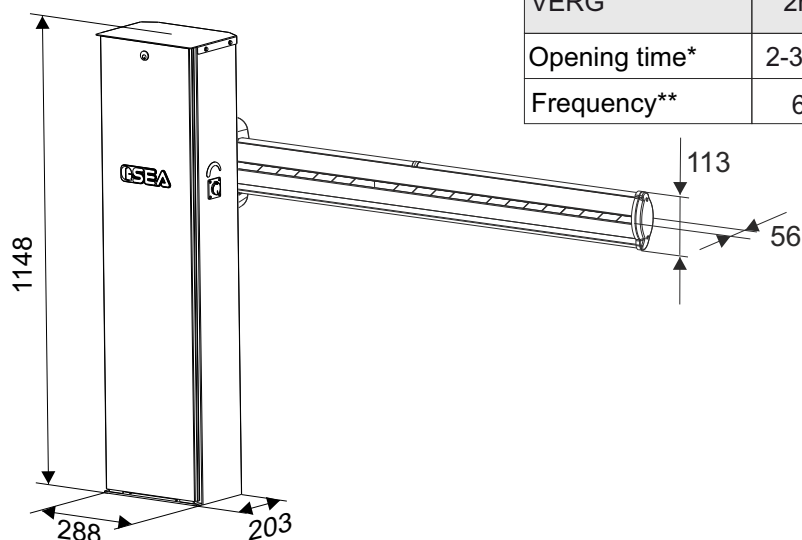

BEAMS RECOMMENDED SPEED

VERG	2m	3m	4m	5m	6m	Articulated beam 3m
Opening time*	2-3 sec	3-4 sec	4-5 sec	5-6 sec	6-7 sec	5-6 sec
Frequency**	60%	50%	45%	35%	30%	35%

*To guarantee longer life of the barrier, SEA recommend to adjust the speed giving an extra time of at least 1 sec from the Max Speed as for this chart.

** SEA grant those performances only for the 1st hour of operation. After 1 st hours cycles can drop up to 50%. Cycles are granted only with slowdown active. Periodically check the balance of the beam.

INSTALLATION INSTRUCTIONS

1) Spring position

Opening on the left

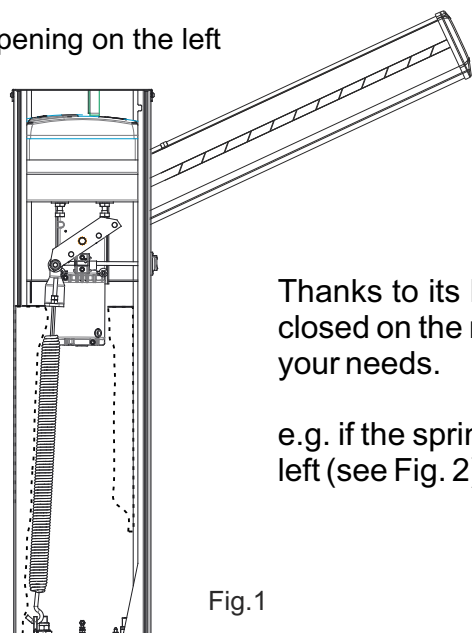

Fig.1



Opening on the right

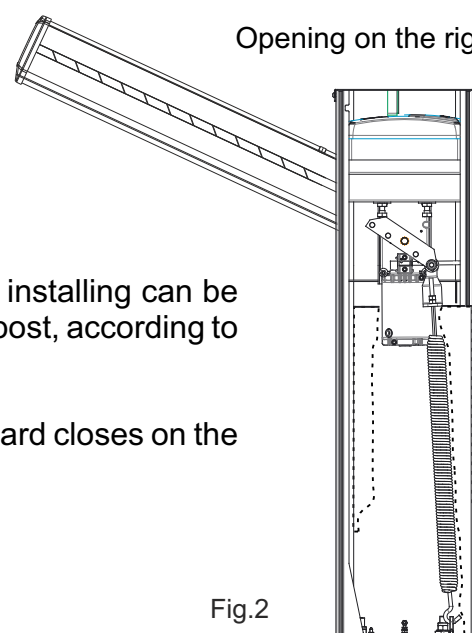

Fig.2

Thanks to its high flexibility, the barrier you are installing can be closed on the right-hand or left-hand side of the post, according to your needs.

e.g. if the spring is on the right-hand side, the guard closes on the left (see Fig. 2).

2) Foundation plate anchoring

- Make a 500 x 500 x 300 mm (depth) hole in the ground.
- Fill the hole with R425 concrete and place the foundation plate as shown in Fig. 3.
- Accurately level the plate.

* The middle hole of the plate must be used for cable routing. Therefore, make sure that the conduit connected to the hole complies with current regulations, before filling the hole with concrete.

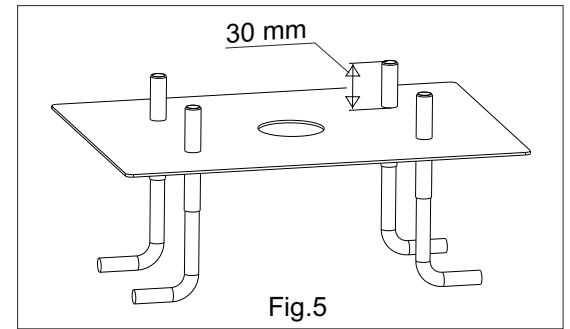
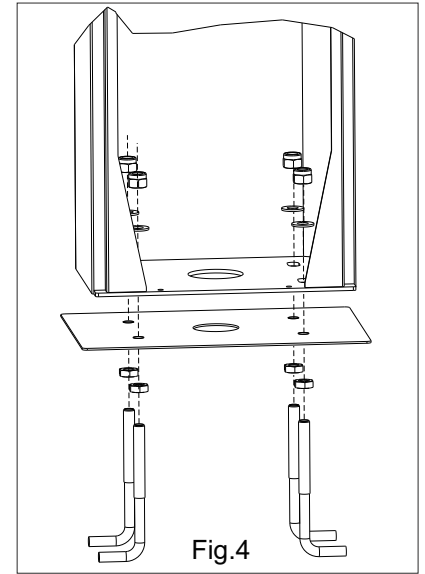
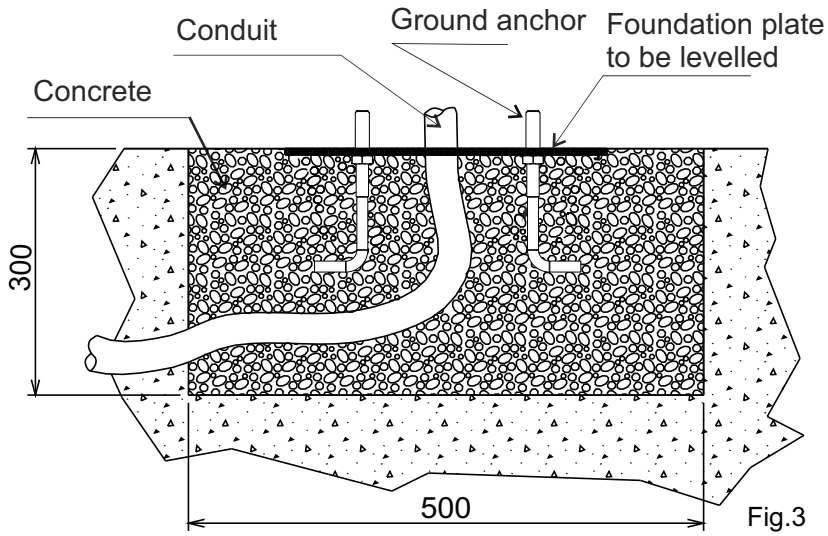

3) Post anchoring on the foundation plate

- Place the casing so that the holes on the base match the screws located on the foundation plate.
- Make sure that the conduit for the cables goes through the large hole of the casing base.
- Insert the bracket for anchoring the spring: A in case of left-hand mounting, B in case of right-hand mounting; the bracket must always be positioned towards the inside as in Fig. 6.
- Fix the casing on the foundation plate, screwing the supplied nuts and washers carefully.

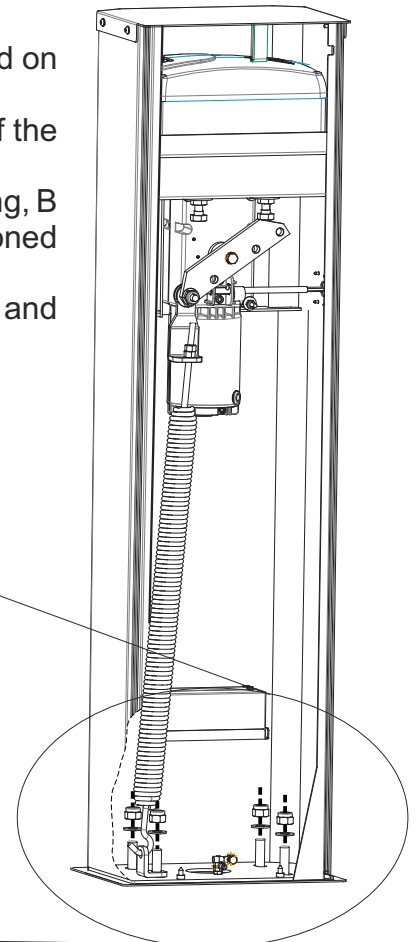
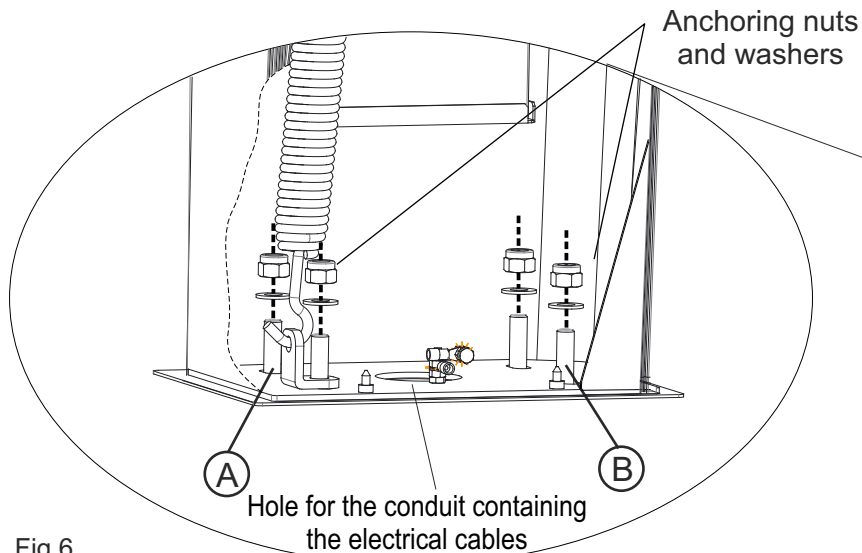

Fig. 6

4) Fixation of the balance

- Fix the bracket for beam fixation (A) into the balance as shown in Fig. 7
- Clamp the nut (B) with a tightening of 40 Nm
- **Lubricate all parts with the provided grease after assembling**

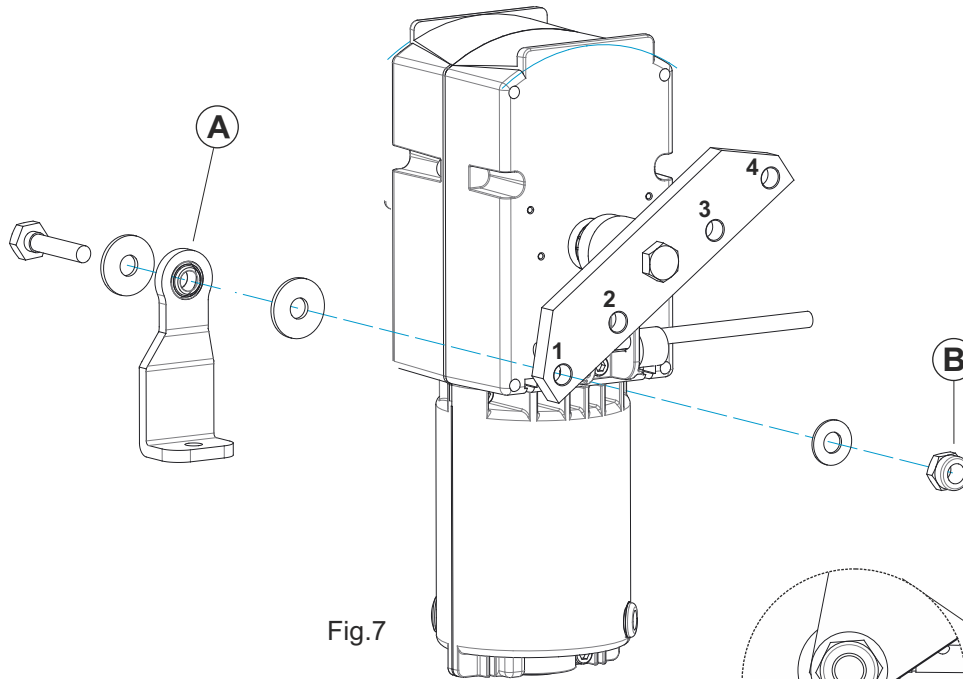

Fig.7

Keep well lubricated with the provided grease

OVAL BEAM

Length (m)	Balance Position	Spring (Ø mm)	Opening Time
3	1 / 4	6	3" ÷ 4"
4	1 / 4	7,5	4" ÷ 5"
5	1 / 4	8,5	5" ÷ 6"
6 *	1/4	9	6" ÷ 7"

* With 6 metres beam length the use of the fork support is recommended

Note: Strictly follow the opening time to avoid bad working

Note: The springs and the bracket of anchorage are supplied with the beam

5) Mounting of the spring

- Anchor the spring on the bracket which has been mounted before (E)
- Insert the rod of the spring into the bracket (C) and insert the nuts (D) without tightening them

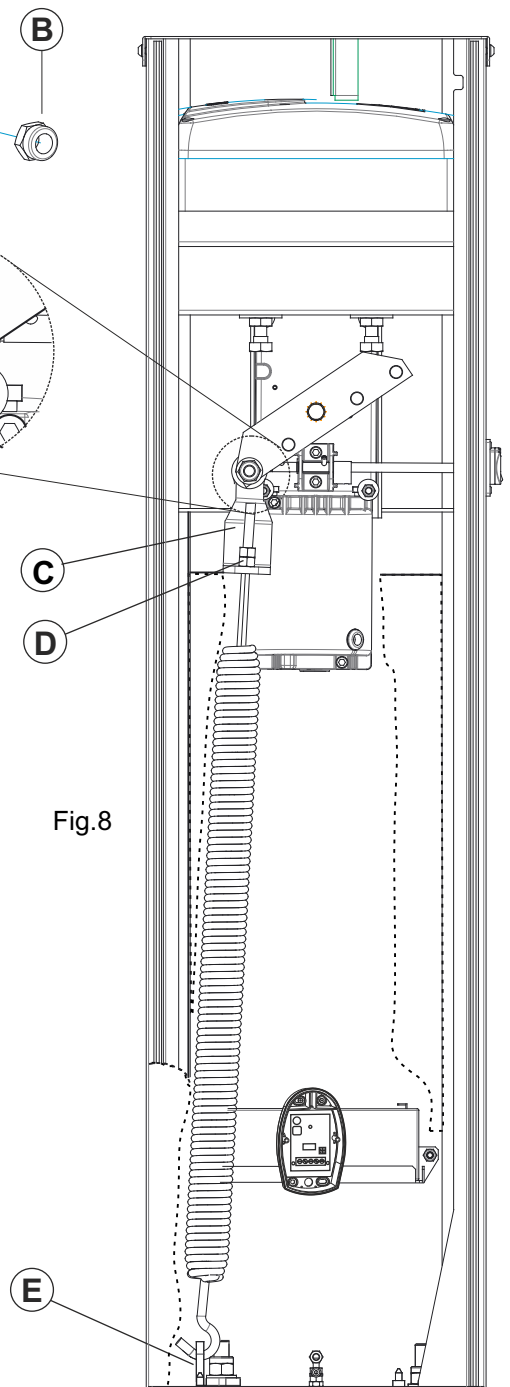

Fig.8

6) Mounting of the oval beam

Note: For 4 m - 5 m - 6m beams it is recommended to use the fork support or the flexible support.

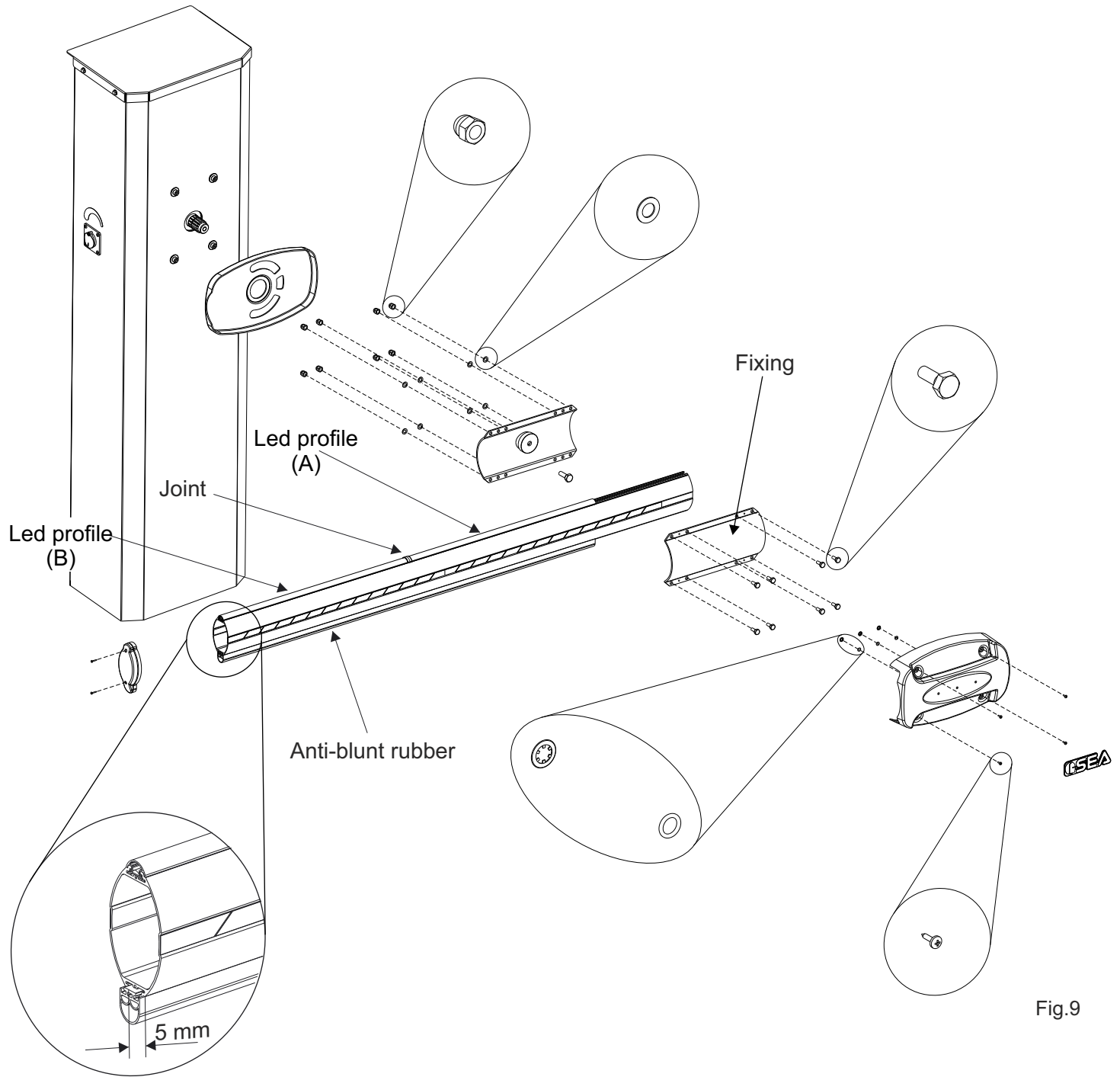

Fig. 9-a

Fig.9

Mount the first segment (A) of the LED profile, positioning it in doorstep on the fixing, mount the joint, fit the second segment (B) of the LED profile and repeat the operation for all segments of the LED profile up to covering the length of the whole beam. The last profile LED must be cut with a hacksaw at the end of the rod (Fig.9-a). Intersperse each segment of the LED profile with a joint.

Mount the anti-blunt rubber so that it comes out from the beam about 5mm (Fig.9-a).

7) Beam balancing

- Release the beam with manual release, so that it is free to be opened and closed manually (Fig.10).
- Place the beam at approx. 45°.
- Loosen or tighten the spring stretching nut until the spring counterbalances the weight of the 45° beam (Fig.10). The best balancing position is obtained when the beam reaches the position shown in Fig. 10.
- After having obtained the balancing, lock the nuts of the spring stretcher with the counter nut and re-block the motor.

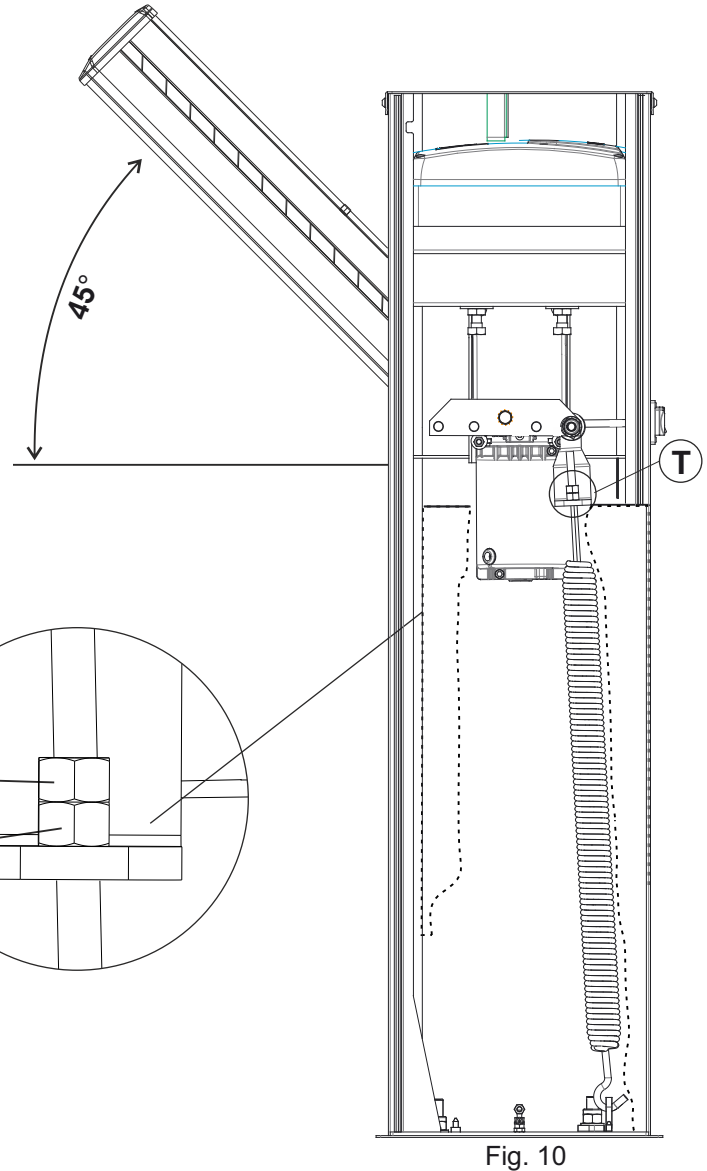

Should the balancing of the beam not be perfect and the length of the spring stretcher (T) be too long, cut it about half of its length.

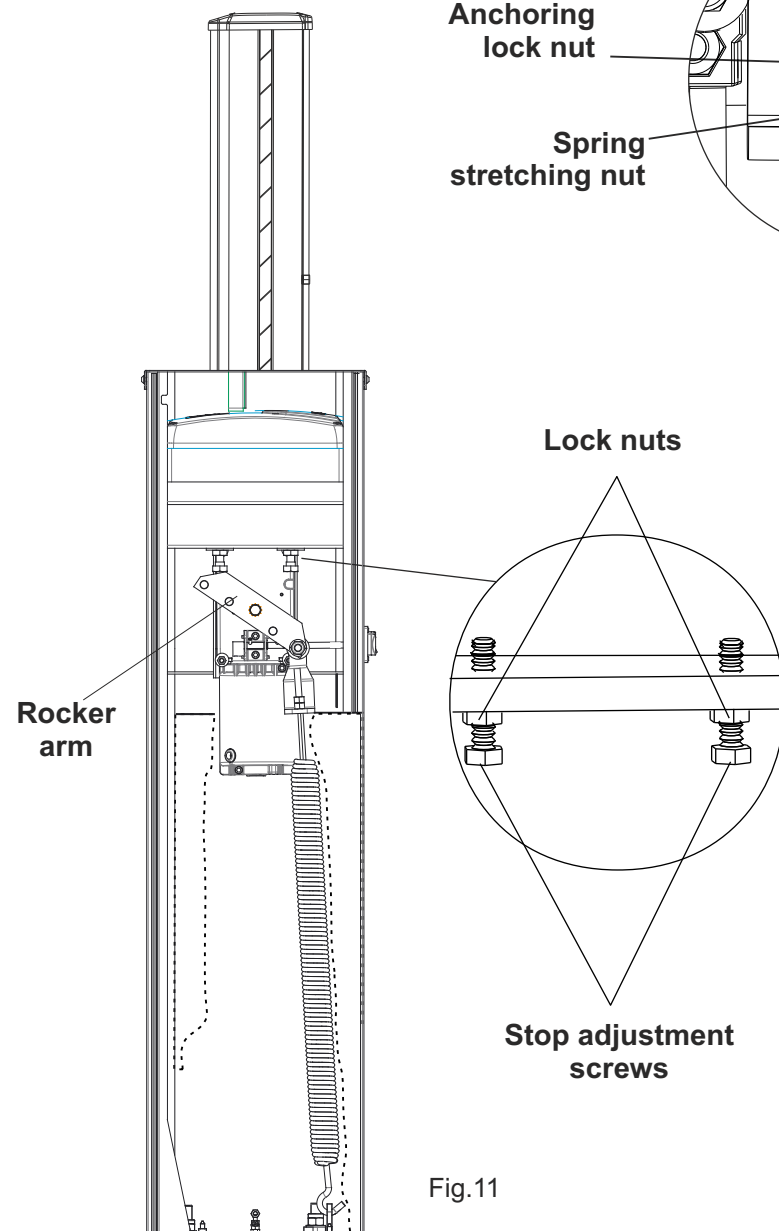

8) Beam levelling



Note: this operation must be carried out only if the beam is not perfectly horizontal (closing stage) or vertical (opening stage) at the end of its stroke.

- Release the beam with the special manual release so that it is free to open and close manually.
- Release the screws of the limit switch on unscrewing the nuts on the mechanical stops (Fig.11).
- Loosen or tighten the stop screws so that the beam is released in its vertical position (opening stage) (Fig. 11) and horizontal position (closing stage).
- After having executed the levelling lock the screws of the limit switch tightening the nuts on the mechanical stops and re-lock the beam.

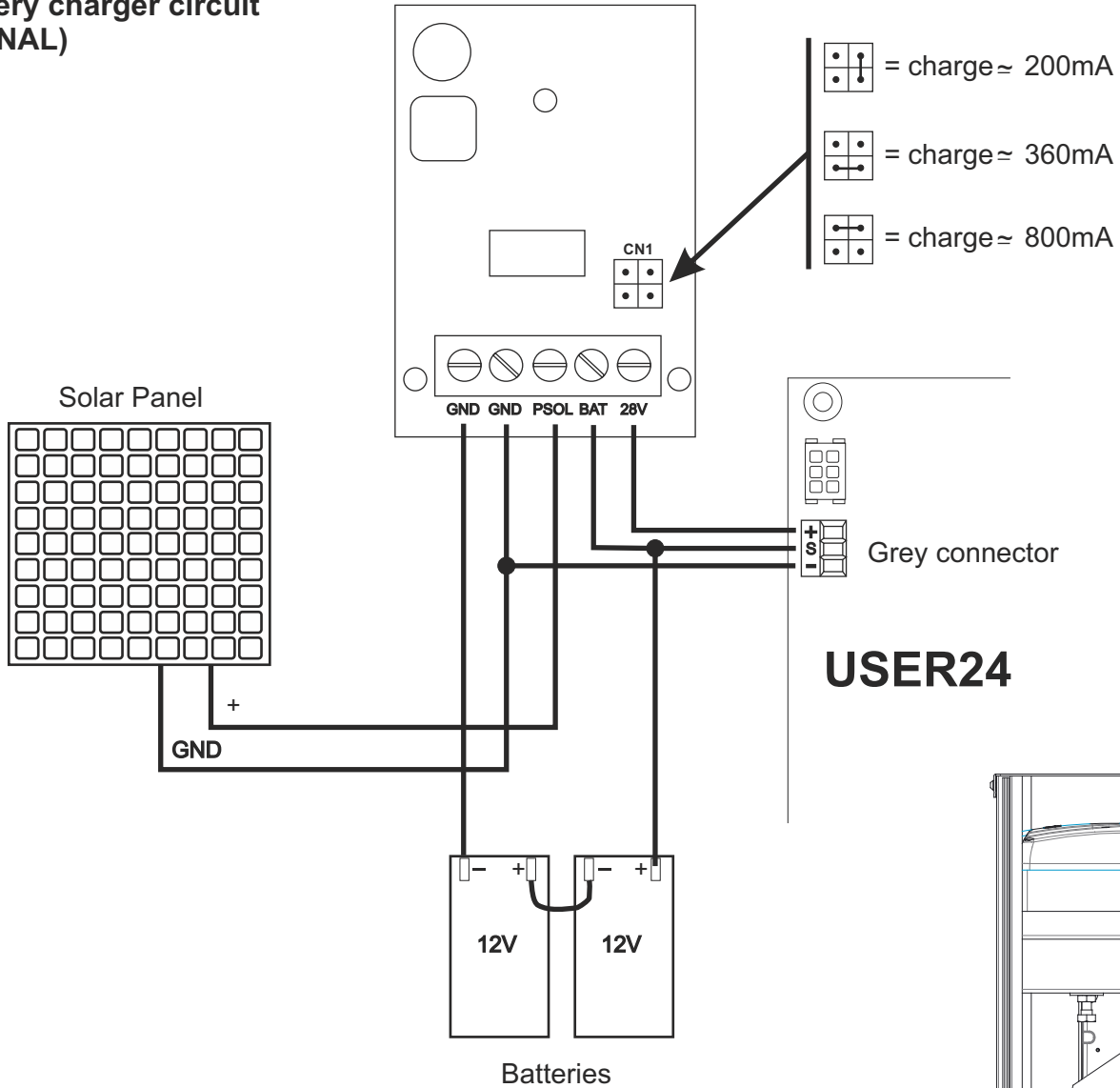
9) Battery charger circuit (OPTIONAL)



Note: For a longer duration of the battery it is recommended to set the charging current according to the following table:

Battery Current (mA)	Battery (Ah)
 800	12 o 16
 360	7
 200	2

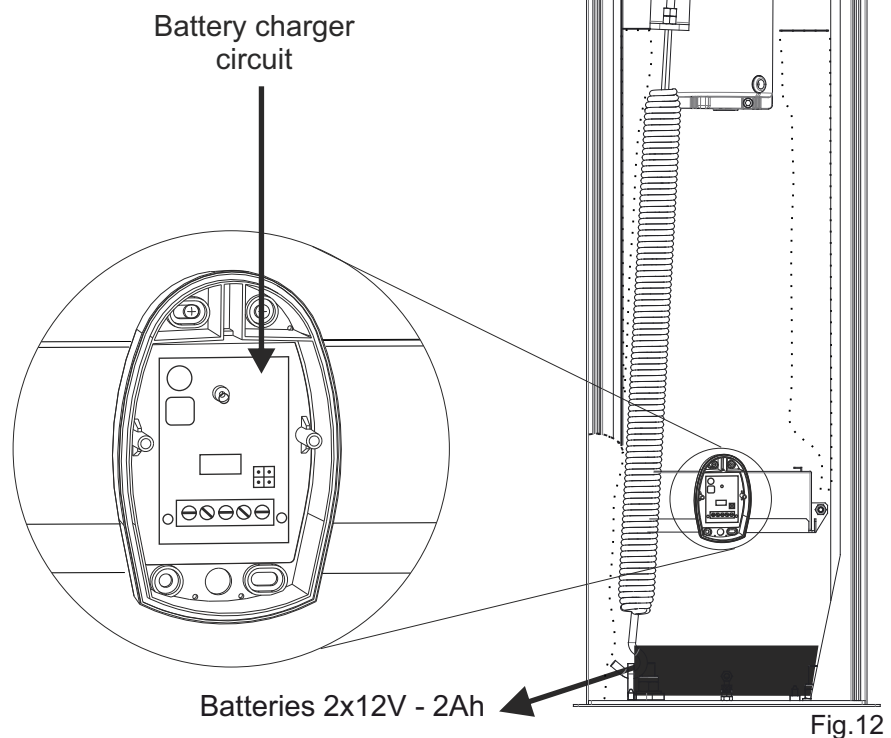

10) Drilling scheme for passage of light power cable

Use hole **A** for assembly of the right beam.

Use hole **B** for assembly of the left beam.

Holes **B** and **A** to be made on carter

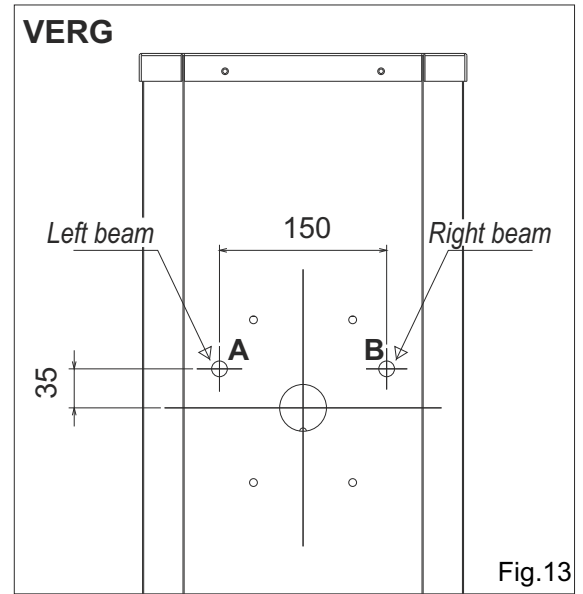

11) Electrical system

Fig. 14 sketches the electrical system that the barrier requires.

The two numbers located near the electrical cables indicate the cable number and section.

Captions:

- 1- VERG electronic control unit
- 2- Transmitting photocell
- 3- Receiving photocell
- 4- Key switch
- 5- Radio receiver
- 6- Flashing light
- 7- Push-button station
- 8- Differential switch

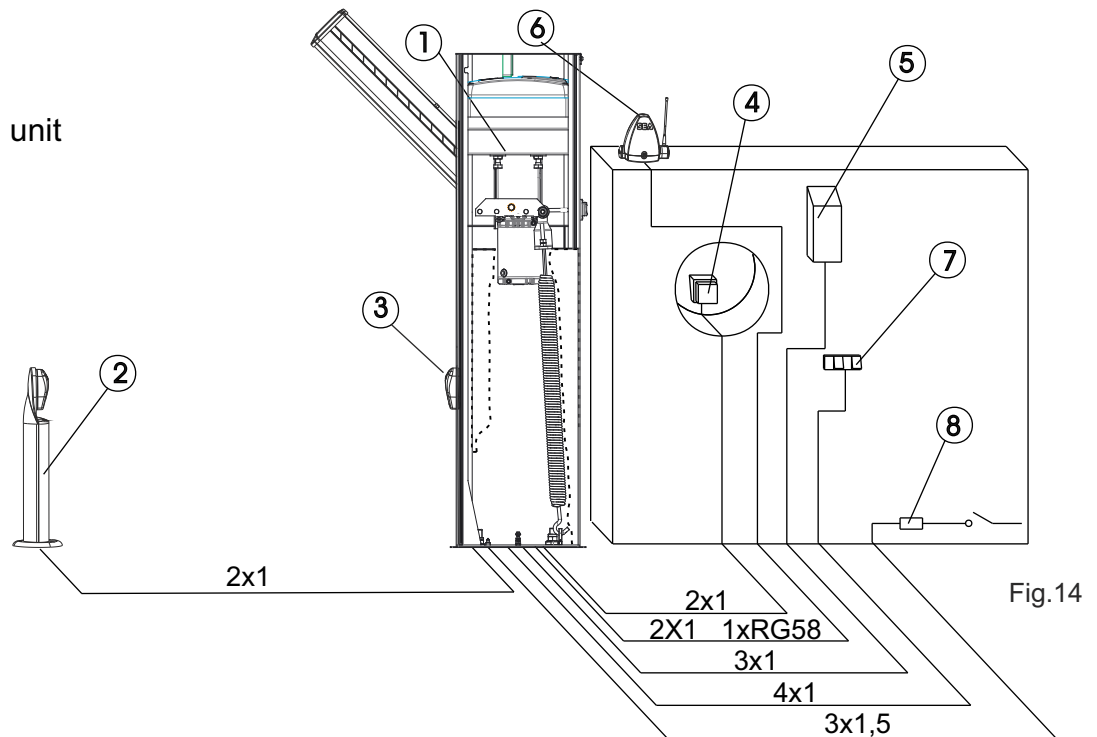

ACCESSORIES FOR VERG



To the attention of users and technicians

12) Release system

To release operate as follows

- Turn the protection cap of the release
- Insert the T shaped key and turn it about 180° into clockwise direction until the beam is released (Fig. 15)
- Open manually the beam

To re-lock operate as follows

- Turn the T-shaped key into anti-clockwise direction (Fig. 16)
- Extract the key
- Re-close the protection cap

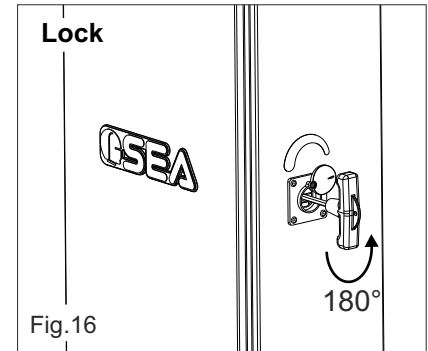
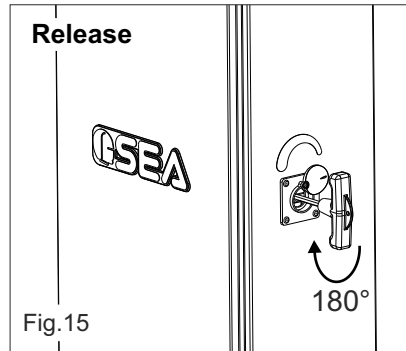

PERIODICAL MAINTENANCE

Check the functionality of the release	Annually
Lubricate the bearing of the balance	Annually
Check the efficiency of the spring	Annually
Check the beam fixing screws and the balance and the casing	Annually
Check the integrity of the connexion cables	Annually
Check the efficiency of the batteries (where included)	Annually
Check and eventually adjust the value of intervention of the anti-crash sensor.	Annually

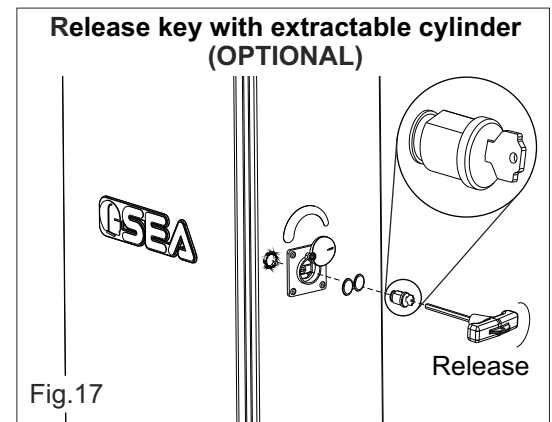

All above mentioned operations must be executed exclusively by authorized installers

NOTES

The electrical installation and the operation logics must comply with current regulations. Keep the power cables (motors, power supply) separated from the control cables (push-buttons, photo-eyes, radio, etc.). Separate conduits should be used to prevent noise issues. **Note: Use "cable clips" and/or "duct/box pipes" fitting close to the control panel box so to protect the interconnection cables against pulling efforts.**

INTENDED USE

VERG system has been designed exclusively for the automation of barriers.

SPARE PARTS

The spare parts orders must be sent to: **SEA S.p.A. Zona Ind.le, 64020 S.ATTO Teramo Italy**

SAFETY AND RESPECT FOR THE ENVIRONMENT

We recommend not to spoil the environment with product and circuit packing material.

STORAGE

STORAGE TEMPERATURE			
T _{min}	T _{max}	Humidity _{min}	Humidity _{max}
-30°C	+60°C	5% without condensation	90% without condensation

The product must be handled using suitable means.

LONG-TERM STOP AND MAINTENANCE

The disassembly and/or stop and /or maintenance of the VERG automation system must be carried out by skilled and expert technicians.

GUARANTEE LIMITS

For the guarantee see the sales conditions on the official SEA price list.

NOTE: THE MANUFACTURER SHALL NOT SHOULD ANY RESPONSIBILITIES IN CASE OF DAMAGE CAUSED BY INAPPROPRIATE, WRONG OR CARELESS USE.

SEA reserves the right to make all the necessary changes and modifications of the products and / or manuals without giving prior notice.

English GENERAL NOTICE FOR THE INSTALLER AND THE USER

1. Read carefully these **Instructions** before beginning to install the product. Store these instructions for future reference
2. Don't waste product packaging materials and /or circuits.
3. This product was designed and built strictly for the use indicated in this documentation. Any other use, not expressly indicated here, could compromise the good condition/operation of the product and/or be a source of danger. SEA S.p.A. declines all liability caused by improper use or different use in respect to the intended one.
4. The mechanical parts must be comply with Directives: Machine Regulation 2006/42/CE and following adjustments), Low Tension (2006/95/CE), electromgnetic Consistency (2004/108/CE) Installation must be done respecting Directives: EN12453 and En12445.
5. Do not install the equipment in an explosive atmosphere.
6. SEA S.p.A. is not responsible for failure to observe Good Techniques in the construction of the locking elements to motorize, or for any deformation that may occur during use.
7. Before attempting any job on the system, cut out electrical power and disconnect the batteries. Be sure that the earthing system is perfectly constructed, and connect it metal parts of the lock.
8. Use of the indicator-light is recommended for every system, as well as a warning sign well-fixed to the frame structure.
9. SEA S.p.A. declines all liability as concerns the automated system's security and efficiency, if components used, are not produced by SEAS.p.A..
10. For maintenance, strictly use original parts by SEA.
11. Do not modify in any way the components of the automated system.
12. The installer shall supply all information concerning system's manual functioning in case of emergency, and shall hand over to the user the warnings handbook supplied with the product.
13. Do not allow children or adults to stay near the product while it is operating. The application cannot be used by children, by people with reduced physical, mental or sensorial capacity, or by people without experience or necessary training. Keep remote controls or other pulse generators away from children, to prevent involuntary activation of the system.
14. Transit through the leaves is allowed only when the gate is fully open.
15. The User must not attempt to repair or to take direct action on the system and must solely contact qualified SEA personnel or SEA service centers. User can apply only the manual function of emergency.
16. The power cables maximum length between the central engine and motors should not be greater than 10 m. Use cables with 2,5 mm² section. Use double insulation cable (cable sheath) to the immediate vicinity of the terminals, in particular for the 230V cable. Keep an adequate distance (at least 2.5 mm in air), between the conductors in low voltage (230V) and the conductors in low voltage safety (SELV) or use an appropriate sheath that provides extra insulation having a thickness of 1 mm.

TERMS OF SALES

EFFICACY OF THE FOLLOWING TERMS OF SALE: the following general terms of sale shall be applied to all orders sent to SEA S.p.A. All sales made by SEA to all costumers are made under the prescription of this terms of sales which are integral part of sale contract and cancel and substitute all apposed clauses or specific negotiations present in order document received from the buyer.

GENERAL NOTICE The systems must be assembled exclusively with SEA components, unless specific agreements apply. Non-compliance with the applicable safety standards (European Standards EM12453 – EM 12445) and with good installation practice releases SEA from any responsibilities. SEA shall not be held responsible for any failure to execute a correct and safe installation under the above mentioned standards.

1) PROPOSED ORDER The proposed order shall be accepted only prior SEA approval of it. By signing the proposed order, the Buyer shall be bound to enter a purchase agreement, according to the specifications stated in the proposed order.

On the other hand, failure to notify the Buyer of said approval must not be construed as automatic acceptance on the part of SEA.

2) PERIOD OF THE OFFER The offer proposed by SEA or by its branch sales department shall be valid for 30 solar days, unless otherwise notified.

3) PRICING The prices in the proposed order are quoted from the Price List which is valid on the date the order was issued. The discounts granted by the branch sales department of SEA shall apply only prior to acceptance on the part of SEA. The prices are for merchandise delivered ex-works from the SEA establishment in Teramo, not including VAT and special packaging. SEA reserves the right to change at any time this price list, providing timely notice to the sales network. The special sales conditions with extra discount on quantity basis (Qx, Qx1, Qx2, Qx3 formula) is reserved to official distributors under SEA management written agreement.

4) PAYMENTS The accepted forms of payment are each time notified or approved by SEA. The interest rate on delay in payment shall be 1.5% every month but anyway shall not be higher than the max. interest rate legally permitted.

5) DELIVERY Delivery shall take place, approximately and not peremptorily, within 30 working days from the date of receipt of the order, unless otherwise notified. Transport of the goods sold shall be at Buyer's cost and risk. SEA shall not bear the costs of delivery giving the goods to the carrier, as chosen either by SEA or by the Buyer. Any loss and/or damage of the goods during transport, are at Buyer's cost.

6) COMPLAINTS Any complaints and/or claims shall be sent to SEA within 8 solar days from receipt of the goods, proved by adequate supporting documents as to their truthfulness.

7) SUPPLY The concerning order will be accepted by SEA without any engagement and subordinately to the possibility to get it's supplies of raw material which is necessary for the production; Eventual completely or partially unsuccessful executions cannot be reason for complains or reservations for damage. SEA supply is strictly limited to the goods of its manufacturing, not including assembly, installation and testing. SEA, therefore, disclaims any responsibility for damage deriving, also to third parties, from non-compliance of safety standards and good practice during installation and use of the purchased products.

8) WARRANTY The standard warranty period is 12 months. This warranty time can be extended by means of expedition of the warranty coupon as follows:

SILVER: The mechanical components of the operators belonging to this line are guaranteed for 24 months from the date of manufacturing written on the operator.

GOLD: The mechanical components of the operators belonging to this line are guaranteed for 36 months from the date of manufacturing written on the operator.

PLATINUM: The mechanical components of the operators belonging to this line are guaranteed for 36 months from the date of manufacturing written on the operator. The base warranty (36 months) will be extended for further 24 months (up to a total of 60 months) when it is acquired the certificate of warranty which will be filled in and sent to SEA S.p.A. The electronic devices and the systems of command are guaranteed for 24 months from the date of manufacturing. In case of defective product, SEA undertakes to replace free of charge or to repair the goods provided that they are returned to SEA repair centre. The definition of warranty status is by unquestionable assessment of SEA. The replaced parts shall remain propriety of SEA. Binding upon the parties, the material held in warranty by the Buyer, must be sent back to SEA repair centre with fees prepaid, and shall be dispatched by SEA with carriage forward. The warranty shall not cover any required labour activities.

The recognized defects, whatever their nature, shall not produce any responsibility and/or damage claim on the part of the Buyer against SEA. The guarantee is in no case recognized if changes are made to the goods, or in the case of improper use, or in the case of tampering or improper assembly, or if the label affixed by the manufacturer has been removed including the SEA registered trademark No. 804888. Furthermore, the warranty shall not apply if SEA products are partly or completely coupled with non-original mechanical and/or electronic components, and in particular, without a specific relevant authorization, and if the Buyer is not making regular payments. The warranty shall not cover damage caused by transport, expendable material, faults due to non-conformity with performance specifications of the products shown in the price list. No indemnification is granted during repairing and/or replacing of the goods in warranty. SEA disclaims any responsibility for damage to objects and persons deriving from non-compliance with safety standards, installation instructions or use of sold goods. The repair of products under warranty and out of warranty is subject to compliance with the procedures notified by SEA.

9) RESERVED DOMAIN A clause of reserved domain applies to the sold goods; SEA shall decide autonomously whether to make use of it or not, whereby the Buyer purchases propriety of the goods only after full payment of the latter.

10) COMPETENT COURT OF LAW In case of disputes arising from the application of the agreement, the competent court of law is the tribunal of Teramo. SEA reserves the faculty to make technical changes to improve its own products, which are not in this price list at any moment and without notice. SEA declines any responsibility due to possible mistakes contained inside the present price list caused by printing and/or copying. The present price list cancels and substitutes the previous ones. The Buyer, according to the law No. 196/2003 (privacy code) consents to put his personal data, deriving from the present contract, in SEA archives and electronic files, and he also gives his consent to their treatment for commercial and administrative purposes.

Industrial ownership rights: once the Buyer has recognized that SEA has the exclusive legal ownership of the registered SEA brand num.804888 affixed on product labels and / or on manuals and / or on any other documentation, he will commit himself to use it in a way which does not reduce the value of these rights, he won't also remove, replace or modify brands or any other particularity from the products. Any kind of replication or use of SEA brand is forbidden as well as of any particularity on the products, unless preventive and expressed authorization by SEA.

In accomplishment with art. 1341 of the Italian Civil Law it will be approved expressly clauses under numbers:

4) PAYMENTS - 8) GUARANTEE - 10) COMPETENT COURT OF LAW



Dichiarazione di conformità
Declaration of Conformity

La SEA S.p.A. dichiara che, con l'installazione degli adeguati dispositivi di sicurezza e di filtraggio disturbi, i prodotti:

SEA S.p.A. declares that by installing the appropriate safety equipment and noise filtering the products:

Descrizione / Description	Modello / Model	Marca / Trademark
VERG 24V L (e tutti i suoi derivati/and all its by-products)	11320006-1	SEA

è costruito per essere incorporato in una macchina o per essere assemblato con altri macchinari per costruire una macchina ai sensi della Direttiva 2006/42/CE:

is built to be integrated into a machine or to be assembled with other machinery to create a machine under the provisions of Directive 2006/42/CE:

è conforme ai requisiti essenziali di sicurezza relativi al prodotto entro il campo di applicabilità delle Direttive Comunitarie 2006/95/CE e 2004/108/CE.

it is conforming to the essential safety requirements related to the product within the field of applicability of the Community Directives 2006/95/CE and 2004/108/CE.

COSTRUTTORE o RAPPRESENTANTE AUTORIZZATO:
MANUFACTURER or AUTHORISED REPRESENTATIVE:

SEAS.p.A.
DIREZIONE E STABILIMENTO:
Zona industriale 64020 S.ATTO Teramo - (ITALY)
Tel. +39 0861 588341 r.a. Fax +39 0861 588344
Http://www.seateam.com

I test sul prodotto sono stati effettuati in configurazione standard e in riferimento alle norme specifiche per la sua classe d'utilizzo.

The products have been tested in standard configuration and with reference to the special norms concerning the classe of use.

(Luogo, data di emissione)
(Place, date of issue)
Teramo, 10/12/2012

L'Amministratore
The Administrator
Ernio Di Saverio



SEA[®]
electronic opening system

Questo articolo è stato prodotto seguendo rigide procedure di lavorazione ed è stato testato singolarmente al fine di garantire i più alti livelli qualitativi e la vostra soddisfazione. Vi ringraziamo per aver scelto SEA.

This item has been produced following strict production procedures and has been singularly tested for the highest quality levels and for your complete satisfaction.
Thanks for choosing SEA.

Cet article a été produit suivant des procédures d'usinage strictes et il a singulièrement été testé afin de garantir les plus hauts niveaux de qualité pour votre satisfaction.
Nous vous remercions d'avoir choisi SEA.

Este artículo ha sido producido siguiendo rigidos procedimientos de elaboración y ha sido probando singolarmente a fin de garantizar los mas altos niveles de calidad y vuestra satisfaccion.
Le agradecemos por haber escogito SEA.

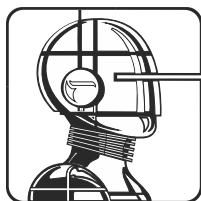

SEA[®]

Sistemi Elettronici
di Apertura Porte e Cancelli
International registered trademark n. 804888



SEA S.p.A.
Zona industriale 64020 S.ATTO Teramo - (ITALY)
Tel. +39 0861 588341 r.a. Fax +39 0861 588344

www.seateam.com

seacom@seateam.com